

WE TAKE BUILDING
AUTOMATION PERSONALLY

en

VARIABLE LIST RDAS...-24C





THANK YOU FOR CHOOSING REGIN!

Ever since Regin was established in 1947, we have developed and marketed products and systems that create good levels of indoor comfort. Today, we are an important player with one of the market's broadest ranges for building automation.

Our goal is to make real estates in the world more energy efficient. Regin is an international group and our products sells in over 90 countries. Thanks to our global presence with strong local representation, we are well aware of the requirements of the market, as well as of how our products and systems function under the most variable conditions. Every year, Regin makes substantial investments in the development of our systems and HVAC-products.

DISCLAIMER

The information in this manual has been carefully checked and is believed to be correct. Regin makes no warranties about the contents of this manual and users are requested to report errors and discrepancies to Regin, so that corrections may be made in future editions. The information in this document is subject to change without prior notification.

Some product names mentioned in this document are used for identification purposes only and may be the registered trademarks of their respective companies.

© AB Regin. All rights reserved.

Rev. B, 2022-01-05

1	RDAS...-24C and Modbus communication.....	5
1.1	Introduction	5
1.2	Models without spring return	5
1.3	Models with spring return	5
2	Comissioning notes.....	6
2.1	General checks	6
2.1.1	Environmental conditions.....	6
2.1.2	Mechanical check (RDAS5-24C, RDAS10-24C, RDAS20-24C and RDAS35-24C).....	6
2.1.3	Mechanical check (RDAS7S-24C and RDAS18S-24C)	6
2.1.4	Electrical check (RDAS5-24C, RDAS10-24C and RDAS35-24C)	6
2.1.5	Electrical check (RDAS7S-24C, RDAS18S-24C and RDAS20-24C).....	6
2.1.6	Rotary direction switch	6
3	Modbus.....	8
3.1	HMI - Human machine interface (RDAS5-24C and RDAS10-24C)	8
3.1.1	Push button operation	8
3.1.2	LED colors and patterns	8
3.1.3	Resetting the device by push button	9
3.2	HMI - Human machine interface (RDAS7S-24C, RDAS18S-24C, RDAS20-24C and RDAS35-24C).....	9
3.2.1	Push button operation	9
3.2.2	LED colors and patterns	10
3.2.3	Resetting the device by push button	10
3.3	Push button addressing	10
3.3.1	Display current address (starting with lowest address digit)	11
3.3.2	Set new address (starting with lowest address digit).....	11
3.3.3	Examples	11
3.4	Commissioning	12
3.4.1	Workflow 1	12
3.4.2	Workflow 2.....	12
4	Variable list.....	14
4.1	Modbus registers.....	14
4.1.1	Register 769 "Status"	15
4.1.2	Supported function codes	15
4.2	Parameter and function description.....	15

I RDAS...-24C and Modbus communication

I.1 Introduction

RDAS...-24C is a range of damper actuators with Modbus communication. The damper actuators are intended to use in ventilation and air conditioning sites to operate air dampers and air throttles. The actuators can be part of a complete ventilation solution, together with other products in the Regin ventilation family.

All available Modbus variables are presented in the variable list in 4 *Variable list*

I.2 Models without spring return

Article	Supply voltage	Power consumption	Running time, rotation	Torque	Max. damper size	Sound power level
RDAS5-24C	24 V AC (20...28 V AC 50/60 Hz)	3VA (2.5 W)	150s/90°	5 Nm	0.8 m ²	28 dB
RDAS10-24C	24 V AC (20...28 V AC 50/60 Hz)	3VA (2.5 W)	150s/90°	10 Nm	1.6 m ²	28 dB
RDAS20-24C	24 V AC/DC (20...28 V AC 50/60 Hz / 24...48 V DC)	2.8 VA (1.7W)	150s/90°	20 Nm	4 m ²	<35 dB
RDAS35-24C	24 V AC (20...28 V AC 50/60 Hz)	8 VA (8W)	125s/90°	35 Nm	6 m ²	43 dB

I.3 Models with spring return

Article	Supply voltage	Power consumption	Running time, rotation	Torque	Max. damper size	Sound power level, actuator	Sound power level, spring return
RDAS7S-24C	24 V AC/DC (20...28 V AC 50/60 Hz / 24...48 V DC)	AC 5VA (3.5W) / DC 3.5W	90s/90°	7 Nm	1.5 m ²	40 dB(A)	61 dB(A)
RDAS18S-24C	24 V AC/DC (20...28 V AC 50/60 Hz / 24...48 V DC)	AC 7VA (5W) / DC 4W	90s/90°	18 Nm	3 m ²	46 dB(A)	71 dB(A)

2 Comissioning notes

All information necessary for commissioning is available in this document. It is available for download from Regin's website, www.regincontrols.com

2.1 General checks

2.1.1 Environmental conditions

Check to ensure that all permissible values are observed.

2.1.2 Mechanical check (RDAS5-24C, RDAS10-24C, RDAS20-24C and RDAS35-24C)

- ✓ Check that the unit is mounted properly and ensure that all mechanical settings correspond to the site-specific requirements. Additionally, ensure that the dampers are shut tight when in the fully closed position.
- ✓ Fasten the actuator securely to avoid side load.
- ✓ Rotary movement check: Manually change the damper setting by pressing the gear train disengagement button and turn the adapter (only if no voltage is applied).

2.1.3 Mechanical check (RDAS7S-24C and RDAS18S-24C)

- ✓ Check that the unit is mounted properly and ensure that all mechanical settings correspond to the site-specific requirements. Additionally, ensure that the dampers are shut tight when in the fully closed position.
- ✓ Fasten the actuator securely to avoid side load.
- ✓ Check the rotary movement: Manually set the damper by turning the adapter using an Allen key, and lock the gear train as per the mounting instructions (only if no voltage is applied).
- ✓ Check the unlocking mechanism of the gear train by turning the Allen key in the direction of 90°. See instructions for RDAS7S-24C and RDAS18S-24C for further information.

2.1.4 Electrical check (RDAS5-24C, RDAS10-24C and RDAS35-24C)

- ✓ Check to ensure that the cables are connected in accordance with the site wiring diagram.
- ✓ The operation voltage AC 24 V (SELV/PELV) must be within the tolerance values.

2.1.5 Electrical check (RDAS7S-24C, RDAS18S-24C and RDAS20-24C)

- ✓ Check to ensure that the cables are connected in accordance with the site wiring diagram.
- ✓ The operation voltage AC 24 V /DC 24...48 V (SELV/PELV) must be within the tolerance values.

2.1.6 Rotary direction switch

The set direction of rotation must be the same as the required direction of the air damper.

The factory setting is clockwise:



Figure 2-1 Clockwise

3 Modbus

3.1 HMI - Human machine interface (RDAS5-24C and RDAS10-24C)

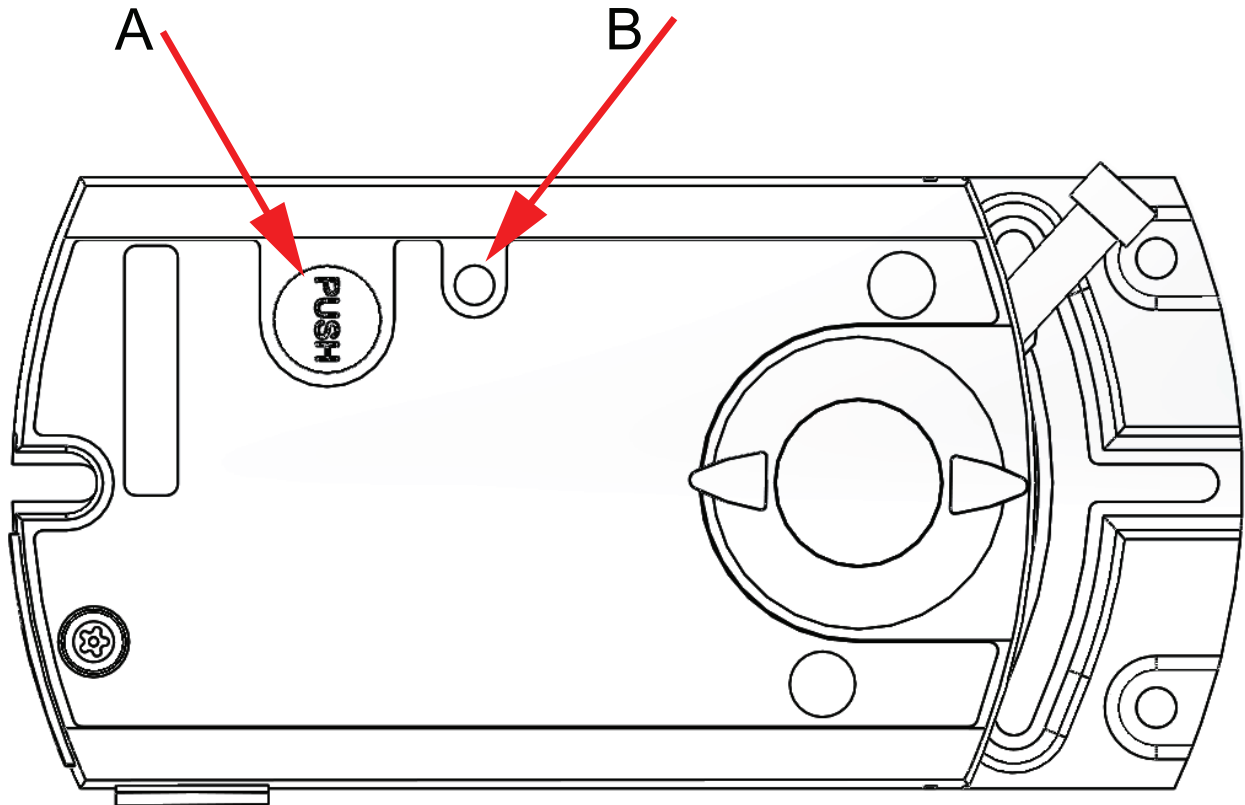

Figure 3-1 HMI - Human machine interface (RDAS5-24C and RDAS10-24C)

A = Push button, B = LED

3.1.1 Push button operation

Activity	Push button operation	Confirmation
Display current address (in reverse order)	Press and hold the button for shorter than 1 second	Current address is displayed, see 3.3.1 <i>Display current address (starting with lowest address digit)</i>
Enter Modbus address with push-button	Press and hold button between 1 and 5 seconds	See description in section 3.3 <i>Push button addressing</i>
Reset to factory settings	Press and hold the button for longer than 10 seconds	Orange LED flashes

3.1.2 LED colors and patterns

Colour	Pattern	Description
Green	Steady	Start-up
	1 second on / 5 seconds off	Fault free operation ("life pulse")
	Flashing	Bus traffic
Orange /green	1 second orange / 1 second green	Device is in override control

Orange	1 second on / 1 second off	Bus parameters not yet configured
Orange	1 second on / 5 seconds off	Backup mode entered
Red	Steady	Mechanical fault / Device jammed
	1 second on / 5 seconds off	Internal error
	0.1 second on / 1 second off	Invalid configuration, e.g. Min = Max

3.1.3 Resetting the device by push button

The damper actuator can be reset by push-button:

1. Press and hold the button for longer than 10 seconds: LED starts flashing orange
2. Release the button while LED still flashes: LED keeps flashing for 3 seconds
3. If the button is pressed within these 3 seconds, the reset is cancelled
4. After these 3 seconds: LED shines red (reset), then green (start-up)

See section 3.3 *Push button addressing* for more information and examples.

3.2 HMI - Human machine interface (RDAS7S-24C, RDAS18S-24C, RDAS20-24C and RDAS35-24C)

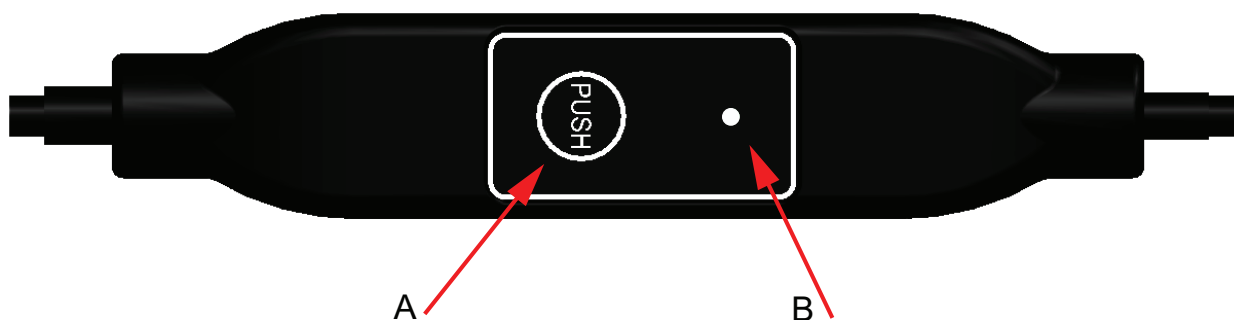

Figure 3-2 HMI - Human machine interface (RDAS7S-24C, RDAS18S-24C, RDAS20-24C and RDAS35-24C)

A = Push button; B = LED

3.2.1 Push button operation

Activity	Push button operation	Confirmation
Display current address (starting with lowest address digit)	Press and hold the button for shorter than 1 second	1-digit: red
		10-digits: green
		100-digits: orange
		If termination is switched on, LED flashes blue 1 time after address display.
		Example: 124 = 4x red, 2x green, 1x orange

Turn bus termination on / off: turn on	1. press the button 3 times	LED flashing and flickering stops (termination mode)
	2. press the button 1 time shortly	LED flashes blue 1 time
	3. press the button until LED shines red	LED shines red (confirmation)
	4. release the button	LED off
		Address display
	LED flashes blue 1 time after address display	
	Normal operation	
Turn bus termination on / off: turn off	1. press the button 3 times	LED flashing and flickering stops (termination mode)
	2. press the button until LED shines red	LED shines red (confirmation)
	3. release the button	Normal operation
Enter Modbus address with push-button	Press and hold button between 1 and 5 seconds	See description in section 3.3 <i>Push button addressing</i>
Reset to factory settings	Press and hold the button for longer than 10 seconds	Orange LED flashes

3.2.2 LED colors and patterns

Colour	Pattern	Description
Green	1 second on / 5 seconds off	Normal operation ("life pulse") without bus traffic
	Flashing	Normal operation ("life pulse") with bus traffic
Orange /green	1 second orange / 1 second green	Device is in override control
Orange	1 second on / 1 second off	Bus parameters not yet configures
	1 second on / 5 seconds off	Backup mode entered
Red	Steady	Mechanical fault, device jammed or manual override
	1 second on / 5 seconds off	Internal error
	0.1 second on / 1 second off	Invalid configuration, e.g. Min = Max
Blue	Flashes 1 time after address display	Bus termination is set active

3.2.3 Resetting the device by push button

1. Press and hold the button for longer than 10 seconds: LED starts flashing orange.
2. Release the button while LED still flashes: LED keeps flashing for 3 seconds.
3. If the button is pressed within these 3 seconds, the reset is cancelled.
4. After those 3 seconds: LED shines red (reset), then the device restarts.

See section 3.3 *Push button addressing* for more information and examples.

3.3 Push button addressing

The Modbus address can be set without a separate tool by using push-button and LED. To display the current address, press button < 1 second.

3.3.1 Display current address (starting with lowest address digit)

Colours	Digits
Red	1-digits
Green	10-digits
Orange	100-digits

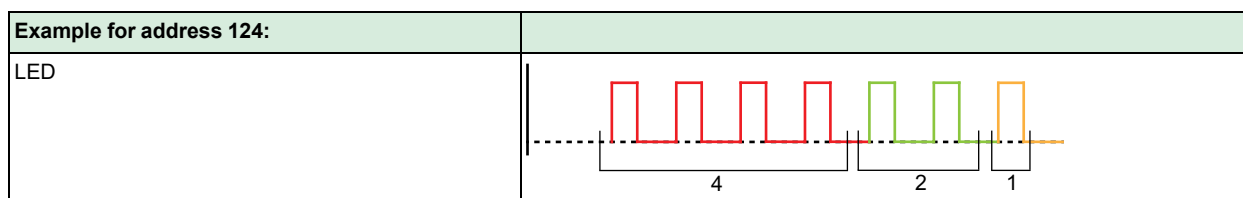

Note! The address is entered and shown starting with lowest address digit, see figure above (124 in the example is starting with 4x red)

3.3.2 Set new address (starting with lowest address digit)

1. Enter addressing mode: press and hold the button for longer than 1 second until LED shines red, then release button (before LED gets dark).
2. Enter digits: press the button n-times -> LED flashes per button press (feedback).
Colours: 1-digits: red / 10-digits: green / 100-digits: orange
3. Store digits: press and hold button until LED shines in colour of next digits -> release button.
4. Save address: press and hold button until LED shines red (confirmation) -> release button.
An address can be stored at any time, i.e. after setting the 1-digits, or after setting the 1- and the 10-digits.
5. Entered address is repeated one times for confirmation.



Note! If button is released before LED shines red, the address is discarded.

3.3.3 Examples

Set address "124":

1. Enter addressing mode: press and hold the button for longer than 1 second until LED shines red, then release button (before LED gets dark).
2. Set 1-digits: Press button 4-times -> LED flashes red per button press
3. Store 1-digits: Press and hold the button until LED shines green - release button
4. Set 10-digits: Press button 2-times -> LED flashes green per button press
5. Store 10-digits: Press button until LED shines orange - release button
6. Set 100-digits: Press button 1-times -> LED flashes orange per button press
7. Store address: Press button until LED shines red - release button
-> address is stored and displayed 1 time for confirmation



Figure 3-3 Example address 124

Set address "50"

1. Enter addressing mode: Press and hold the button for longer than 1 second until LED shines red, then release button (before LED gets dark).
2. Skip 1-digits: Hold button pressed until LED shines green - release button
3. Set 10-digits: Press button 5-times -> LED flashes green per button press
4. Store address (skip 100-digits): hold button pressed until LED shines red - release button -> address is stored and displayed 1 time for confirmation

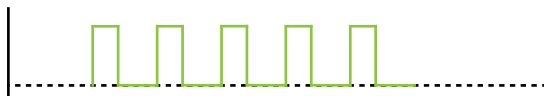

Figure 3-4 Example address 50

Set address "5"

1. Enter addressing mode: Press and hold the button for longer than 1 second until LED shines red, then release button (before LED gets dark).
2. Set 1-digit: Press button 5-times -> LED flashes red per button press
3. Store address (skip 10-digit and 100 digit): Press button until LED shines red -> address is stored and displayed 1 time for confirmation



Figure 3-5 Example address 5

3.4 Commissioning

3.4.1 Workflow 1

During commissioning check/set the following:

- ✓ Bus configuration (address, baudrate, transmission mode, and optionally termination). The default address 255 allows to mount and power multiple actuators at the same time without interfering with each other.
- ✓ Damper actuator parameters (opening directions, position limits, positions adaptation etc.) can be checked via the Modbus register.

3.4.2 Workflow 2

The devices can be configured over bus if the pre-commissioning settings allow for a connection between the Modbus master / programming tool and peripheral devices (i.e. non-conflicting addresses and matching baudrate / transmission format).

- ✓ Full configuration over bus. If the address is unique per segment when powered up, the device can be accessed by the Modbus master (or programming tool) and the address and other parameters can then be set to the definitive values.
- ✓ Partial configuration over bus: If the address is not unique per segment when powered up, each device must get a non-conflicting address before connecting it to the bus, either by using the address input with push-button (see 3.3 *Push button addressing*) or by setting the address to 246 with push button press and hold between 5 and 10 seconds. After addressing all devices, the remaining configuration can be done over the bus using the default settings for baudrate (auto-baud) and transmission mode for the Modbus master.
- ✓ Overwriting the bus configuration over bus uses a timeout. If "1 = Load" is not written into Reg 768 within 30 seconds, all values are discarded.

Example: Table shows bus configuration registers before and after changing them over bus.

Reg.	Name	Pre-commissioning	New value (example)
764	Modbus Address	246	12
765	Baudrate	0 = auto	1 = 9600
766	Transmission Format	0 = 1-8-E-1	3 = 1-8-N-2
767	Termination	0 = Off	0 = Off
768	Bus Conf. Command	0 = Ready	1 = Load

4 Variable list

4.1 Modbus registers

Reg.	Name	R/W	Unit	Scaling	Range / enumeration
Process Values					
1	Setpoint	RW	%	0.01	0...100
2	Override control	RW	-	-	0 = Off / 1 = Open / 2 = Close 3 = Stop / 4 = GoToMin / 5 = GoToMax
3	Actual position	R	%	0.01	0...100
256	Command	RW	-	-	0 = Ready / 1 = Adaption / 2 = Selftest 3 = RelnitDevice/ 4 = RemoteFactory Reset

Parameters					
257	Opening direction	RW	-	-	0 = CW / 1 = CCW
258	Adaptive Mode	RW	-	-	0 = Off / 1 = On
259	Operating Mode	RW	-	-	1 = POS
260	MinPosition	RW	%	0.01	0...100
261	MaxPosition	RW	%	0.01	0...100
262	Actuator Running Time	R	s	1	150
513	Backup Mode	RW	-	-	0 = Go to BackupPosition 1 = Keep last position 2 = Disabled
514	Backup Position	RW	%	0.01	0...100
515	Backup Timeout	RW	s	1	0...65535
516	Startup Setpoint	RW	%	0.01	0...100
764	Modbus Address	RW	-	-	1...247 / 255 = "unassigned"
765	Baudrate	RW	-	-	0 = auto / 1 = 9600 / 2 = 19200 3 = 38400 / 4 = 57600 / 5 = 76800 6 = 115200
766	Transmission Format	RW	-	-	0 = 1-8-E-1 / 1 = 1-8-O-1 2 = 1-8-N-1 / 3 = 1-8-N-2
767	Bus Termination	RW	-	-	0 = Off / 1 = On
768	Bus Conf. Command	RW	-	-	0 = Ready / 1 = Load / 2 = Discard
769	Status	R	-	-	See below, Register 769 "Status"

Reg.	Name	R/W	Value	Example
Device information				
1281	Factory Index	R	Two bytes, each coding an ASCII char.	
1282	Factory Date HWord	R	Two bytes, the lower coding the Year (hex)	
1283	Factory Date LWord	R	High byte: coding the month (hex) Low byte: coding the day (hex)	
1284	Factory SeqNo HWord	R	Hword + Lword = HEX-representation of Sequence number:	Read 1284 -> 000A
1285	Factory SeqNo LWord	R		Read 1285 -> A206 AA206(hex) -> 696838 (dec) -> Device has sequence number 696838

1409	ASN [Char_16...15]	R	Each register: Two bytes, each coding an ASCII char. ASN is coded beginning with reg. 1409	Example: 0x47 44 = GD 0x42 31 = B1 0x38 31 = 81 0x2E 31 = .1 0x45 2F = E/ 0x4D 4F = MO -> ASN is GDB181.1E/MO
1410	ASN [Char_14...13]	R		
1411	ASN [Char_12...11]	R		
1412	ASN [Char_10...9]	R		
1413	ASN [Char_8...7]	R		
1414	ASN [Char_6...5]	R		
1415	ASN [Char_4...3]	R		
1416	ASN [Char_2...1]	R	Reserve	

4.1.1 Register 769 "Status"

Status			
Bit 00	1 = reserved	Bit 06	1 = Adaption done
Bit 01	1 = Backup mode active	Bit 07	1 = Adaption in progress
Bit 02	1 = reserved	Bit 08	1 = Adaption error
Bit 03	1 = reserved	Bit 09	1 = Selftest failed
Bit 04	1 = Mechanical fault, device jammed or manual override	Bit 10	1 = Selftest passed
Bit 05	1 = Nom. lifetime exceeded	Bit 11	1 = Invalid configuration

4.1.2 Supported function codes

Function codes	
03 (0x03)	Read Holding Registers
04 (0x04)	Read Input Register
06 (0x06)	Write Single Register
16 (0x16)	Write Multiple Registers (Limitation: Max. 120 registers within one message)

4.2 Parameter and function description

Function	Reg.	Description
Override control	2	<p>The actuator can be operated in override control for commissioning / maintenance purposes or system-wide functions (e.g. night-cooling).</p> <ul style="list-style-type: none"> ✓ Manual override: When the gear disengagement is used to freely adjust the damper position, a mechanical jam will be detected if a mismatch between setpoint and actual position persists for more than 10 seconds. ✓ Remote override: The actuator enters this state when an override command is sent over the bus ✓ Available commands: <ul style="list-style-type: none"> - Open /Close (depends on opening direction) - Min / Max (depends on Min/Max settings) - Stop
Adaptive positioning	258	<ul style="list-style-type: none"> ✓ For air dampers where the opening range is smaller than the nominal opening range 0...90°, the feedback signal can be adapted to have the actual opening range represented as 0...100%. ✓ Using adaptive positioning makes the actuator driving to its end positions at the first startup after activating the adaptive positioning. ✓ To trigger the adaptation again after the first startup, either the command "CalibrateAdaption" (Write "1" into register no. 256), or the adaptive positioning can be turned off and on again.

Variable list

Backup mode	513, 514, 515	<ul style="list-style-type: none"> ✓ In case the communication to the controller is lost, the device can be configured to go into a defined state. ✓ Default setting mode is "keep last setpoint", i.e. in case of communication loss, the device controls to the last received setpoint. ✓ If the backup mode is enabled, it can be configured as follows: <ul style="list-style-type: none"> - go to a predefined backup position - keep current position
Restarting the device	256	<p>Restarting is possible by:</p> <ul style="list-style-type: none"> ✓ Power-reset (turning operating voltage off and on) or ✓ by "ReInitDevice" command. <p>-> Device re-initializes and sets all process values to defaults.</p>
Reset		<p>The actuator supports the following re-initialization / reset behaviour:</p> <ul style="list-style-type: none"> ✓ Local reset by push-button ✓ Remote reset: Using "RemoteFactoryReset" command <p>Effect of reset: Process values: set to default values.</p> <ul style="list-style-type: none"> ✓ Parameters: <ul style="list-style-type: none"> - Application and actuator parameters are set to factory defaults. - Network parameters are reset only in case of local reset, not by remote reset (otherwise there will be loss of communication). ✓ Following parameters are not reset: Counters, status flags, device info, and factory data.
Self test	256	<p>When triggered, the self test drives the actuator to the detected limits and sets the flags in register 769 according to the result (bit 09 = 1 -> "failed" or bit 10 = 1 -> "passed").</p> <p>The self test is not passed when the limits were not reached from the lower end (results in jam). If the Min/Max limits can be exceeded, the self test is not evaluated as failed.</p>



HEAD OFFICE AB Regin, Box 116, SE-428 22 Källered • Visiting address: Bangårdsvägen 35, SE-428 36 Källered
Phone: +46 (0)31 720 02 00 • Fax: +46 (0)31 720 02 50 • info@regincontrols.com • www.regincontrols.com