

Caratteristiche tecniche

- **Materiale:** acciaio inossidabile resistente agli acidi (AISI 316)
- **Pressione max di funzionamento:**
TT1 = 40 bars
TB1 = 200 bars

Technical Features

- **Material:** acid proof stainless steel (AISI 316)
- **Max operating pressure:**
TT1 = 40 bars
TB1 = 200 bars

Note

Prima del montaggio del sensore riempire il pozzetto con dell'olio o della pasta termoisolante.

Application note

Fill some oil or heat transfer compound in the thermowell before mounting the sensor.



Tabella dei valori standard **Table of standard values**

Filetto "F" - Thread "F"		SW
3/8" BSP	M18 x 1,5	24 mm
1/2" BSP	M20 x 1,5	24 mm
3/4" BSP	M24 x 2	27 mm
Lunghezza d'immersione "U" Immersion length "U"		
50 mm – 100 mm – 150 mm – 200 mm		

Tabella codifica *Ordering code*

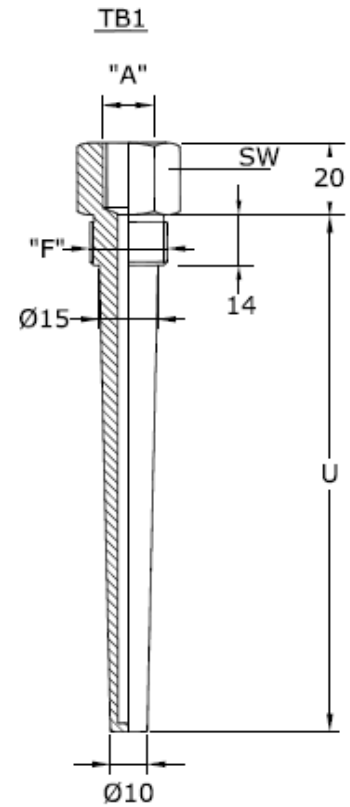