

Installation and Operating Instruction for B.E.G. - Occupancy detectors PD11-M-1C-FLAT/PD11-S

1. Product information

- Extremely slim design with spring clips for easy and time-saving installation directly in suspended ceilings
- Remote controllable occupancy detector **LUXOMAT®** PD11-M-1C-FLAT-FC for indoor applications in the version master with circular detection area
- One switching channel for switching light
- Configuration and operation with the optional remote control possible **LUXOMAT®** IR-PD-1C (Accessories)
- Version as Master/Slave

2. Operation

The presence detector controls the light automatically according to people present (movements) and the ambient brightness.

The integrated light sensor constantly measures the ambient light and compares it with the brightness level on the detector. If the ambient light is sufficient, lighting will not be switched on.

If the ambient light level is below the brightness level, a movement activates the lighting in the room.

The detector switches the light off, if there is enough natural light for 15 min. or until the follow-up time do not recognize any movement in the room.

3. Safety information

Work on the 230 V mains supply may only be carried out by qualified professionals or by instructed persons under the direction and supervision of qualified skilled electrical personnel in accordance with electrotechnical regulations.

Disconnect supply before installing!

This device is not suitable for disconnection.

4. Mounting

A circular opening of diameter 44 mm must be produced in the ceiling.

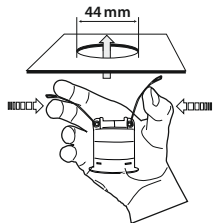

Having connected up the cables in accordance with regulations, the detector is inserted into the opening as shown in the drawing opposite and fixed into position with the assistance of the spring clips.



For mounting into luminaires use the supplied clamp ring and remove the spring clips.

In Master/Slave-operation the master device must always be installed at location with least daylight.

5. Position LEDs

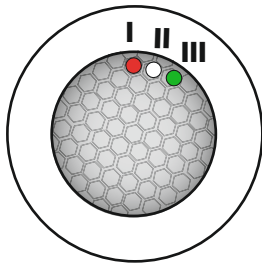

LED I red
LED II white
LED III green

6. Self test cycle/Startup behavior

The product enters an initial 60-second self-test cycle, when the supply is first connected. During this time the device does not respond to movement and stays on.

The initialization mode can be changed by using the remote control.

After the self-test cycle (60s), the detector is ready for operation. There are no further settings necessary. The factory settings of brightness threshold and delay time are explained in the technical data.

7. Wiring diagram

Standard mode with Master/Slave

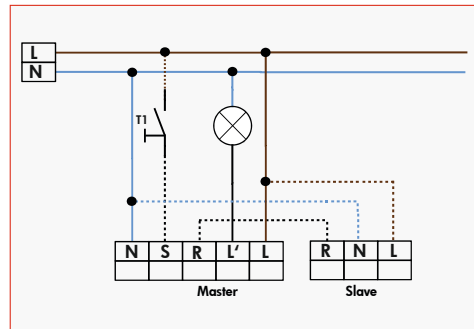

Connected slaves must have the same phase as the master.

8. Range

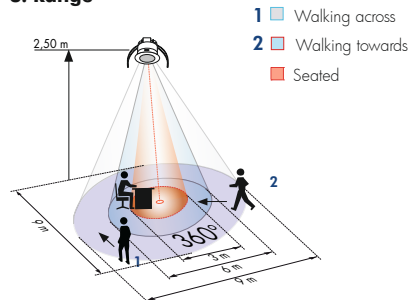

9. Exclude sources of interference

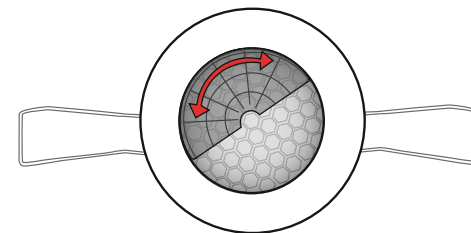

If the detection zone is too large, or areas covered that should not be monitored, use the blinds to reduced or limited those areas.

10. Technical data

Power supply: 110-240VAC, 50/60 Hz
Power consumption: ca. 0.35 W
Ambient temperature: -25°C – +50°C
Degree of protection/class: IP20 / II
Switching power / contact: 2300 W cos φ=1
 1150 VA cos φ=0.5, μ-Contact
 500Lux, 10 min.
Factory reset:
Recommended height for mounting: 2 - 3 m
Range of coverage Ø H 2,50 m / T = 18°C: seated 3 m / tangential 9 m / radial 6 m
 circular 360°
Area of coverage:
Brightness threshold: 10 - 2000 Lux
Follow-up time: 5 - 30 min.
 Settings can be changed by using the optional remote control
Dimensions: H 60 x Ø 52 mm

Technical data PD11-Slave

Power supply: 110-240VAC, 50/60 Hz
Impulse output: Optocoupler max. 2 W
Impulse duration: 9 s

CE Declaration of Conformity:

This product respects the directives concerning
 1. electromagnetic compatibility (2014/30/EU)
 2. low voltage (2014/35/EU)
 3. restriction of the use of certain hazardous substances in electrical and electronic equipment (2011/65/EU)

11. Article / Part nr. / Accessory

Article	FC
PD11-M-1C-FLAT-FC	92583
PD11-S	92593

LUXOMAT® Remote control:

IR-PD-1C (incl. wall bracket)	92520
IR-PD-Mini	92159

12. Manual switching

S-terminal:

By pressing the pushbutton, the phase can be given to the S terminal.
 To turn on or off, press the light briefly. The light will remain on or off, as people are detected plus the follow-up time.

R-terminal:

The R terminal is used for connecting the slave to the master. Alternatively, the phase can be set by a switch on the R terminal. If the phase is longer than 10 sec. on, the detector switches to permanent mode, as long as the pushbutton is closed.

13. LED-functional indicators

LED function indicators after each mains recovery (60sec. initialisation period)	
Operating state	LED function indicators
Factory program active	White, red and green flash in quick succession for 10 sec., then initialisation indicators, see below
	Indicator unprogrammed
Standard mode	Red flashes

LED function indicators during operation	
Process	LED function indicators
Motion detection	Red flashes on each detected movement
Too bright detected	Green flashes
Light measurement active	Green flashes once every 10 sec.

14. Putting into operation of the remote control IR-PD-1C (optional)

Remote control LUXOMAT® IR-PD-1C

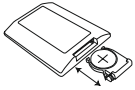

Check Battery: Open battery compartment by pressing the plastic springs together and removing the battery-holder.

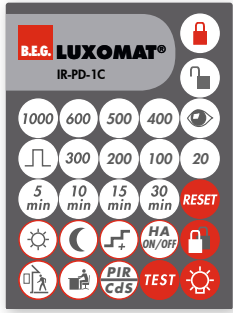

Wall bracket for remote control IR-PD-1C

15. Settings by remote control when open

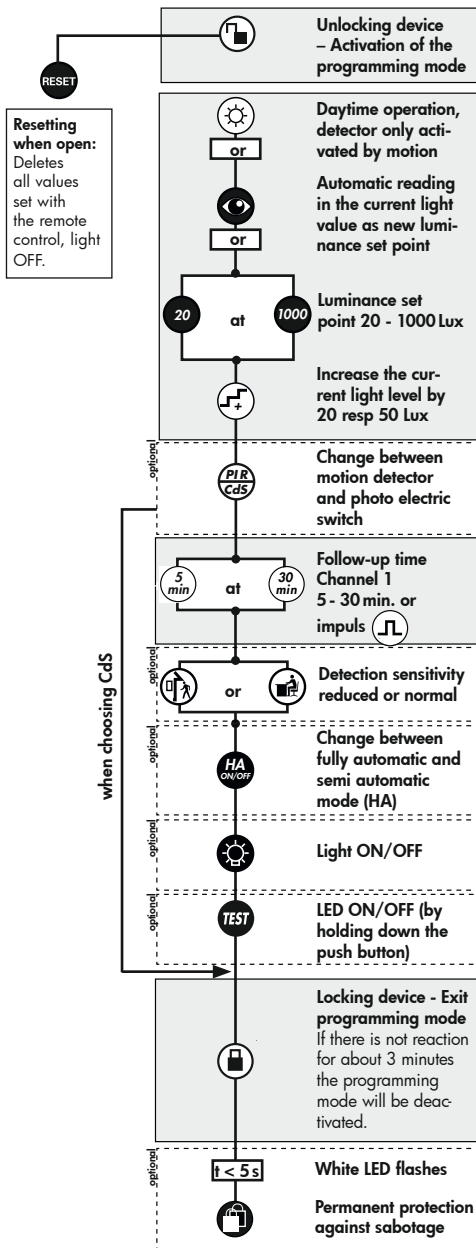

16. Key functions in closed state

- Light ON/OFF during the detection of motion plus follow-up time; Activation of the 12 h-ON/OFF-function by holding down the push button
- Activation/Deactivation of the test function
- Switches channel off and is immediately active again, exits all timers, interruption of light measurement
- Changes to "open" state

17. Explanation of the remote control button functions

17a. In the initialisation period/during self-test cycle

- Turn off or turn on the detector during the self-test cycle of 60 sec. The final state is active. Factory settings of the light is on during initialization.

Initialization mode INI-OFF the detector does not turn on after the power supply voltage. A movement switch on the detector after 60 seconds.

- 12 h Light ON/OFF (party function)**
Activated by "Light" - push button
- Deactivated by "Reset" - push button (default)

- Corridor function**
Activated by "outside" - push button
- Deactivate by "inside" - push button (default)

- Forced shutdown**
Activated by "sun" - push button
- Deactivate by "moon" - push button (default)

17b. In opened state

- This push button opens the detector and the following functions can then be programmed.

Attention: The detector is closed automatically:

- after every voltage recovery
- after 3 minutes

- The state changes to "closed". In the first 5 seconds, the white LED flashes every 0.5 seconds. During this time, sabotage protection can be activated.

- The device distinguishes between 2 procedures:

- **Reading in with lighting switched on:**
The switch-on value is determined automatically.
Determining the switch-on value:
1. Press the "eye" push button
2. Switch off the light (2 seconds later)
3. Read in the brightness
4. Switch-on value = Read brightness

- **Reading in with lighting switched off:**
When the push button is pressed, the current brightness is specified as the switch-on value. The switch-off value is determined automatically.

- If the brightness has been modified, the switch-off threshold is recalculated.

- Each time the push button is pressed, the device increases the current switch-on value in increments of 20 lux for a current switch-on value of < 100 lux and in increments of 50 lux for a current switch-on value of > 100 lux.

- Standard sensitivity for most applications
- Reduced sensitivity for outdoor applications

When the pulse function is active, a pulse of 1 sec. is generated every 9 sec. If the pulse function is activated via remote control, the pause between 2 pulses can be modified. After activating the function via the "Pulse" push button, select the desired time within 5 sec.:

$\left(\frac{5}{min}\right) = 9\text{sec.}, \left(\frac{10}{min}\right) = 10\text{sec.}, \left(\frac{15}{min}\right) = 15\text{sec.}, \left(\frac{30}{min}\right) = 30\text{sec.}$

18. Switch-off threshold brightness

- If the switch-on threshold has been modified by the potentiometer or remote control, the switch-off threshold stored in the EEPROM is deleted and is then recalculated on the next activation.

Determining the switch-off value

- Switch on for 5 min. with dark and motion
- Light OFF for 2 sec.
- Internal calculation of the switch-off value

- If the eye push button is pressed, the switch-off threshold is recalculated. See also Remote control → Eye section 

3. Switch-off delay

If the determined switch-off threshold is exceeded during operation, the detector only switches off after a delay of approx. 15 minutes. This compensates for any brief fluctuations in the brightness.

19a. Behaviour of external push button/IR "Light"

The "Corridor" and "Light ON/OFF" functions are mutually exclusive. If both are activated, the detector performs the corridor function.

The behaviour when the push button is pressed is defined as follows:

Corridor function activated

Light ON:

Push button pressed briefly: Light OFF → Active after 5 sec.

Push button held down: Light OFF → Active after 5 sec.

Light OFF:

Push button pressed briefly: Light ON as long as motion + Lag time

Push button held down: Light ON as long as motion + Lag time

Party function 12 h Light ON/OFF activated

Light ON:

Push button pressed briefly: Light OFF → Active after 5 sec.

Push button held down: 12 h OFF

Light OFF:

Push button pressed briefly: Light ON as long as motion + Lag time

Push button held down: 12 h ON

Corridor- und Party function 12 h Light ON/OFF deactivated

Light ON:

Push button pressed briefly: Light OFF as long as motion + Lag time

Push button held down: Light OFF as long as motion + Lag time

Light OFF:

Push button pressed briefly: Light ON as long as motion + Lag time

Push button held down: Light ON as long as motion + Lag time

19b. Behaviour of external push button/IR "Forced shutdown"

Forced shutdown active

Light OFF:

Light OFF: Push button pressed briefly: Light ON for approx. 30 min., then forced shutdown if the set brightness is still exceeded.

20. Fully automatic and semi automatic mode

(see functions IR-PD-1C)

Fully automatic operation

In this operating mode, the lighting switches automatically on and off for increased comfort, depending on presence and brightness.

- Channel 1 switches on in the event of motion if "dark" is detected.

Semi automatic operation

In this operating condition, in order to gain increased savings, the lighting is energized only after being manually switched on.

Switch-off takes place automatically or manually.

The semi automatic mode basically behaves like the fully automatic one. However, the difference is that switching-on must always be carried out manually!

As many (closer-contact) buttons as desired can be wired in parallel on the "S" button input (ON/OFF).

Triggering in semi automatic mode: If the detector switches off in semi automatic mode (lag timer elapsed), the detector is switched on again within 10 sec. by motion (despite semi automatic mode).

21. Reset of the detector

If the permanent sabotage protection is activated, the detector can be released again as follows:

- Switch off the power supply and switch it back on
- Let the sensor to initialize for 31 to 59 secs.
- Switch off the power supply again
- Apply power again and wait for for the self testing
- Press the unlock

Pushing the "RESET" button on the remote control, in opened mode, will delete all of the values which was set by the remote control (beside of INI ON/OFF) and set the detector back to it's factory reset (500 lux, 10 min.).

22. LED-functional indicators remote control

LED function indicators after each mains recovery (60sec. initialisation period)			
Operating state	LED function indicators		
Factory program active	White, red and green flash in quick succession for 10 sec., then initialisation indicators, see below		
	Indicator unprogrammed	Indicator programmed	Indicator also when forced shutdown is activated
Standard mode	-	red flashes quickly	Every 5 sec., 4 x white, red and green in quick succession
12 h ON/OFF active	Red and green flash	Red and green flash quickly	Every 5 sec., 4 x white, red and green in quick succession
Corridor active	Red and white flash	Red and white flash quickly	Every 5 sec., 4 x white, red and green in quick succession
12 h ON/OFF & corridor active	Red, green and white flash	Red, green and white flash quickly	Every 5 sec., 4 x white, red and green in quick succession
CdS active	-	Red and white flash	Then <u>no</u> red LED for motion detection

LED function indicators during operation	
Process	LED function indicators
Semi-automatic mode active	White is ON
Corridor active	White ON 1 sec. and OFF 4 sec. aus
Corridor and semi-automatic mode active	White ON 4 sec. and OFF 1 sec.
12 h ON/OFF function active	Red and green flash alternately
IR command	White flashes once
IR-command „Open“ and Sabotage active	white and green flashes once
Permanent on/off	red flashes