

# KNX Generation 6

## ST and DX application description

### Index

<b>1. General</b>	<b>3</b>
1.1 KNX bus basics	3
1.2 Symbols	3
1.3 Overview	3
<b>2. The basic principles of motion detection</b>	<b>4</b>
2.1 Introduction	4
2.2 Motion detection by B.E.G.'s KNX detectors	4
2.3 Function of a motion detector	4
2.4 Difference between occupancy and motion detectors	4
2.5 Light analysis	5
2.6 Switching mode and regulation mode	5
2.7 Detector functional groups	5
2.8 Detector modes	6
2.9 Light output (A1)	6
2.10. HVAC outputs A2 to A4	6
2.11 Slave output	7
<b>3. Basic settings of the detector</b>	<b>7</b>
3.1 Start delay for the detector	7
3.2 Test mode	7
3.3 LED indicators	7
3.4 Sound sensor	8
3.5. Temperature measurement	9
3.6 IR remote controls	9
3.7 Regulation via remote control as a percentage	9
3.8 IR PIN	9
<b>4. Light measurement</b>	<b>9</b>
4.1 Basic principles	9
4.2 Reflection factor	10
4.3 Types of light measurement	10
4.3.1 Weighted measurement	10
4.3.2 Smallest measured light value	10
4.3.3 Adjusting the measured value using the B.E.G. infrared lux meter IR-LM (item no. 93030)	11
4.3.4 Adjustment of the measured value using external values	11
4.4 Send brightness value	12
<b>5. Detector outputs</b>	<b>13</b>
5.1 Occupancy detector (switching)	13
5.1.1 Operating modes	13

5.2 Twilight detector	13
5.3 A1: Light output (operation mode switching)	13
5.3.1 Manual influence	13
<b>6. Follow-up time</b>	<b>14</b>
6.1 Setting the follow-up time	14
6.2 Overwrite follow-up time	14
6.3 Triggering	14
6.4 Waiting period at the end of the follow-up time in semi-automatic mode	14
6.5 Individual follow-up times of the sensors (NOTE DEVICE VARIANT)	14
<b>7. Switch-on threshold</b>	<b>15</b>
7.1 Adjust switch-on threshold	15
7.2 Overwrite switch-on threshold	15
7.3 Additional threshold	15
7.4 Calculation of the switch-off threshold	15
7.5 Waiting period after daylight-dependent switch-off in semi-automatic mode	16
<b>8. Switching output</b>	<b>16</b>
8.1 Switching object	16
8.2 Value object	16
8.3 Switching and value object	16
8.4 Scene number	16
8.5 Cyclical sending	17
<b>9. Additional functions</b>	<b>17</b>
9.1 Manual switch-on with sufficient ambient light	17
9.2 Status or function after manual switch-off or end of follow-up time	17
9.3 Orientation light (switching)	18
9.3.1 Brightness (of orientation light) LEDs in percent	18
9.3.2 Movement analysis	18
9.3.3 Orientation light function	18
9.4 Night light (switching)	18
9.4.1 Brightness (of night light) LEDs in percent	18
9.4.2 Night light function	18
9.5 After bus voltage return	19
9.6 Orientation light and night light after manual switch-off	19
9.7 Orientation light and night light global control of slave LEDs	19
9.8 Central OFF	19
9.9 Lock	19
9.9.1 Apply time limit to lock	19
9.9.2 Upon bus voltage return	19
9.10 Behaviour upon bus voltage return	20
9.11 Additional settings for motion sensor(s) (NOTE DEVICE VARIANT)	20
9.11.1 Safety delay	20
9.11.2 Same settings for all sensors (NOTE DEVICE VARIANT)	20
9.11.3 Sensitivity sensor	21
9.11.4 Sensitivity configurable	21

9.12 Sound sensor.....	21	17.2 Remote control (5 buttons) for end-customers (item no. 93398).....	31
<b>10. Occupancy detector (operation mode offset switching).....</b>	<b>21</b>	17.2.1 Operating mode: "Switching".....	31
10.1 Switch-on threshold for switching channel 1 in lux.....	22	17.2.2 Operating mode "Regulation".....	32
10.2 Brightness level measured at the window side while group 2 is switched on (in percent).....	22	17.2.3 Operating mode "Shutters/blinds".....	32
<b>11. Occupancy detector (operation mode regulation).....</b>	<b>22</b>	17.2.4 Operating mode "Scene".....	33
11.1 Set value brightness.....	22	17.2.5 General settings of the 5-button remote control.....	33
11.2 Set value brightness overwritable.....	22	17.3 Bidirectional smartphone app (with IR adapter, art. no. 92726).....	34
11.3 Additional set value/fixed value.....	22	17.3.1 Basic parameter settings.....	35
11.3.1 Fixed value in percent.....	22	17.3.2 Device parameters light output (A1).....	36
<b>12. Regulating outputs.....</b>	<b>22</b>	17.3.3 Device parameters (A2-A4).....	36
12.1 Startup behaviour.....	23	17.3.4 Slave output settings (A4).....	37
12.1.1 Soft start.....	23	17.3.5 Commands for basic settings.....	37
12.1.2 Jump to a fixed value.....	23	17.3.6 Commands for light output (A1).....	37
12.1.3 Jump to a calculated value.....	23	17.3.7 Commands for channels A2-A4.....	38
12.2 Learning time after start.....	23	<b>18. Short presence.....</b>	<b>38</b>
12.3 Hysteresis.....	23	<b>19. Self-adjustment of follow-up time.....</b>	<b>38</b>
12.4 Minimum regulation time/maximum regulation step.....	24	<b>20. Presence simulation.....</b>	<b>38</b>
12.5 Regulation minimum.....	24	<b>21. Internal pushbutton.....</b>	<b>39</b>
12.6 Switch-off delay for regulation minimum $\leq 10\%$ .....	24	<b>22. Logic functions.....</b>	<b>39</b>
12.7 Waiting period after switch-off at regulation minimum in semi-automatic mode.....	24	<b>23. Summary of variants and functions.....</b>	<b>42</b>
12.8 Light groups 2 and 3.....	24	<b>24. List of data point types.....</b>	<b>42</b>
12.9 Cyclical sending.....	24		
<b>13. External commands.....</b>	<b>25</b>		
<b>14. Additional functions in regulation mode.....</b>	<b>25</b>		
14.1 Orientation and night light (regulation).....	25		
14.2 Burn-in function (lamp).....	25		
14.3 Adjustment of the dimming curve.....	26		
<b>15. Slave (SL).....</b>	<b>26</b>		
15.1 Locking time.....	26		
<b>16. HVAC channels (A2-A4).....</b>	<b>27</b>		
16.1 Follow-up time.....	27		
16.2 Switch-on threshold.....	27		
16.3 Switching output.....	27		
16.4 HVAC mode.....	27		
16.5 Additional functions.....	28		
16.6 Projector/corridor.....	28		
16.7 Central OFF.....	28		
16.8 Lock.....	28		
16.9 Motion sensors.....	28		
16.10 Sound sensor.....	28		
<b>17. Remote control/smartphone app.....</b>	<b>28</b>		
17.1 Remote control (27 buttons) for configuration (item no. 92123).....	28		
17.1.1 Special functions.....	29		
17.1.2 Overview of remote control functions.....	30		

## 1. General

### 1.1 KNX bus basics

To understand these instructions, it is assumed that a KNX commissioning or configuration course has been taken.

In order to work with the B.E.G. applications, you must first import them into ETS. ETS is supported from version 4.

### 1.2 Symbols

In the following application description, various symbols are used for clarity. These symbols are briefly explained here.

#### Attention:

This symbol denotes sections of text which absolutely must be read, in order to avoid mistakes in project configuration and commissioning.

#### Recommendation:

This symbol denotes parameter settings which experience has shown to lead to optimal usage of the equipment.

### 1.3 Overview

The KNX Gen6 family from B.E.G. comprises a large number of detectors. The family is divided into series: PD2N, PD4N, PD9, PD11 are series with different detection areas and designs. In addition, there are specially designed series for wall mounting (Indoor 180, Indoor 140-L) and a series for outdoor use (RC-plus next). Within a series, there may also be detectors with special properties. For example, there is PD4 detector that is specially designed for corridors (C) and one for great heights (GH).



The individual series are available in up to three different software versions. The BA- (Basic) variant has basic functions, the ST- (Standard) variant offers a wider range of functions and the DX- (Deluxe) variant offers the greatest functionality. For example, presence simulation is only available in the DX version.

	Device variants		
	BA	ST	DX
Switching mode	X	X	X
Regulation mode		X	X
Offset switching mode		X	X
Number of HVAC outputs	1	3	3
Remote control (bidirectional)		X	X
End-customer remote control			X
Temperature sensor			X
Sound sensor			X
Logic module			X
Presence simulation			X
Internal push button			Indoor 140-L
Internal orientation light			Indoor 140-L
Slave output		X	X
Slave input		X	X
Burn-in function		X	X
Parameter change via object		X	X
Self-adjusting follow-up time		X	X

	Device variants		
	BA	ST	DX
Short presence		X	X
Direction detection		X	X
Daylight-dependent switch-off		X	X

#### Software version and functions

Most series are available for various installation modes. A ceiling mount version (FC-) and a flush-mounting version (FM-) are available. In addition, a surface-mount (SM-) base can also be used with the FM version to make it suitable for surface mounting (see table below). The range of functions is not limited by the different installation variants but depends on the software version selected.

		Installation variants		
		FC	FM	SM
93380	PD2N-KNX-BA-FC	X		
93381	PD2N-KNX-BA-FM		X	
93304	Accessory: SM assembly kit		X	X

#### Installation variants

There are three different ETS applications for the KNX Gen6 family. These are based on the variants BA, ST and DX. They are independent of the series. The BA application can be used for the BA device variants PD2N and Indoor 180. The ST application can be used for the ST series PD2N, PD4N and Indoor 180. The DX application can be used for the DX device variants PD2N, PD4N, PD9, PD11, Indoor 180, Indoor 140-L and RC-plus next.

		Application		
		BA	ST	DX
93360	PD2N-KNX-DX-FC			X
93361	PD2N-KNX-DX-FM			X
93362	Indoor 180-KNX-BA-FM	X		
93363	Indoor 180-KNX-ST-FM		X	
93364	Indoor 180-KNX-DX-FM			X
93380	PD2N-KNX-BA-FC	X		
93381	PD2N-KNX-BA-FM	X		
93382	PD2N-KNX-ST-FC		X	
93383	PD2N-KNX-ST-FM		X	
93384	PD4N-KNX-ST-FC		X	
93385	PD4N-KNX-ST-FM		X	
93386	PD4N-KNX-DX-FC			X
93387	PD4N-KNX-DX-FM			X
93388	PD4N-KNX-C-DX-FC			X
93389	PD4N-KNX-C-DX-FM			X
93390	PD9-KNX-DX-FC			X
93391	PD9-KNX-GH-DX-FC			X
93392	PD11-KNX-FLAT-DX-FC			X
93393	Indoor 140-L-KNX-DX-FM			X
93394	RC-plus next 230-KNX-DX white			X
93395	RC-plus next 230-KNX-DX black			X

		Application		
		BA	ST	DX
93399	PD4N-KNX-GH-DX-SM			X

### Version overview

As a single ETS application can be used with different series, it may be the case that a certain series does not support all functions of the application due to differing hardware components. For example, a PD2N has only one sensor for motion detection. A PD4N, in contrast, has four sensors. The sensitivity of the sensors can be adjusted using the DX application, i.e. so that four parameters are visible. If the detector only has one sensor, then three of the four parameters will have no function. The push button function is another example. This can only be used with the Indoor 140-L, as it has two push buttons.

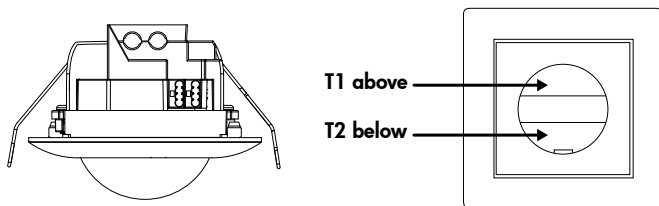

	PD2	PD4	PD4-GH	PD9	PD11	Indoor 140-L	Indoor 180	RC-plus next
Number of light sensors	2	2	1	1	1	1	1	1
▶ Weighting of internal/external sensor	X	X						
Number of motion sensors	1	4	3	1	1	1	1	3
▶ Direction detection		X	X					X
Internal push button						2		
▶ Push button module						X		
Internal orientation light						X		
▶ Night light function						X		

### Hardware-dependent functions

## 2. The basic principles of motion detection

### 2.1 Introduction

In order to ensure a simple introduction to this application description, the general functions of occupancy and motion detectors will first be explained. These are motion detection and light analysis.

### 2.2 Motion detection by B.E.G.'s KNX detectors

The KNX detectors work on a passive infrared system, which registers heat movements and converts them to signals that can be analysed by a processor. The most important factor in motion detection is the right choice of the mounting location.

#### ⚠ Mounting location

The occupancy detector should be mounted so that the main direction of motion is always tangential (side-to-side across the device). The light analysis should always take place at the darkest point of the room. This is the only way to be sure that there is enough light in the room.

⚠ The following sources of interference can lead to unwanted triggering, since they can also produce differences in temperature:

1. radiant heaters,
2. ventilation systems which emit hot or cold air,
3. lights directly in the detection area.

Accordingly, the detector must be positioned far from these sources.

- ⓘ If even the smallest movements are to be recognised (e.g. working at a computer keyboard), we recommend that you choose a mounting location directly above the desk. This means that detection can be assured.
- ⓘ Please always follow the mounting height given for the devices. Smaller mounting heights reduce the range. Higher mounting heights increase the range while reducing the detection sensitivity.

### 2.3 Function of a motion detector

A motion detector automatically switches the light on when a person is present (2). The ambient brightness level must be below the preset switch-on threshold for this to happen. If it is above the threshold, the light is not switched on (1).

After the detector has detected the last movement, the preset follow-up time begins. Once this time has elapsed, the light is automatically switched off (3). If the detector detects another movement within the follow-up time, the follow-up time is restarted.

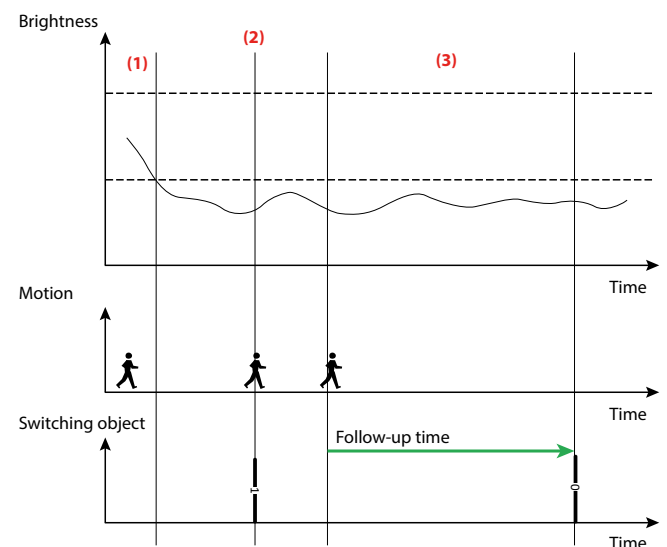

### 2.4 Difference between occupancy and motion detectors

Occupancy and motion detectors both automatically control the light, depending on people being present (motion) and on ambient light levels.

Both detector types switch the light on if ambient light levels are below a switch-on threshold (which can be set on the device) and movement is detected.

A motion detector switches the light off again once no more movement is detected after a follow-up time, i.e. the light remains switched on so long as movements are detected (independent of the lighting level) plus follow-up time. By contrast, an occupancy detector additionally switches the light off, independently of movement, once the ambient light level has been above the calculated switch-off threshold for a minimum time (see section 2.5).

## 2.5 Light analysis

The occupancy detector switches the light automatically, depending on the people being present (movements) and on ambient light. The light sensor integrated into the detector continually measures ambient light and compares it with the preset switch-on threshold or set value in the detector. If the ambient light is sufficient, the lighting is not switched on (1). If the ambient light is below the preset set value brightness, any movement in the room will cause the lighting to switch on (2). The occupancy detector switches the lighting off even if a person is present if there is enough natural light (3) or no movement is detected in the room for a given follow-up time.

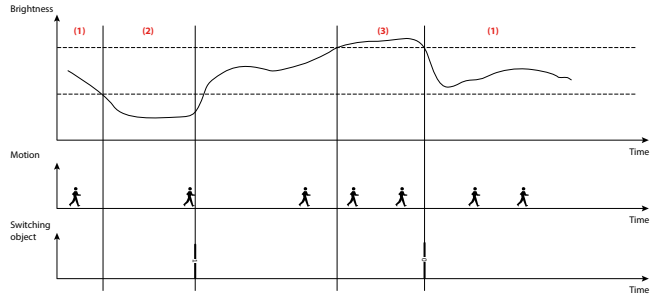

## 2.6 Switching mode and regulation mode

The detector can be operated in three modes: offset switching, switching and regulation mode. In switching mode and offset switching mode, the light is switched on and off using 1-bit switching telegrams. For this, a switch actuator is required on the actuator side. In regulation mode, a dimming actuator is required. 1-byte dimming telegrams (percent values) are sent to the bus.

The desired brightness level for the room can be freely selected. In switching mode, a switch-on threshold is used. This specifies the brightness threshold under which the detector should switch on the light. If a threshold of 500 lux is set, and the ambient light (daylight) level is 200 lux, the detector switches the light on when motion is detected (1). The increase in light caused in the selected lamp is measured (2). With a 600 lux increase in light, the detector switches the light off (3) as soon as the sum of the increase in light and the rise in ambient light reaches 1100 lux. Therefore the selected light level (increase in light) is no longer available. The ambient light is now 500 lux (1100 lux - 600 lux), which is exactly the value defined as brightness threshold.

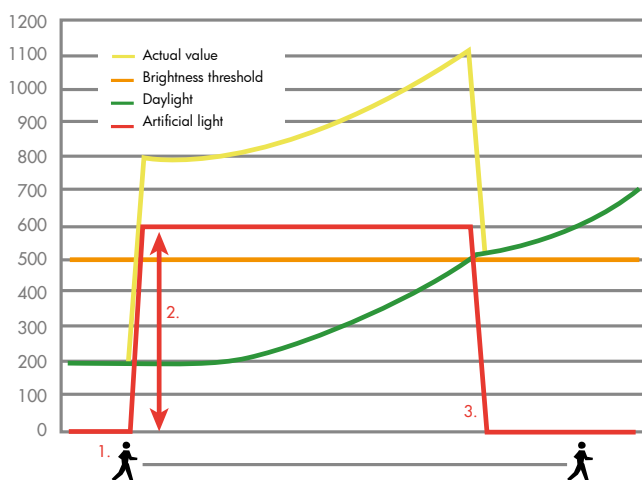

In regulation mode, the term used is not brightness threshold, but set value brightness. Here, the detector sends dimming telegrams to the bus. If the ambient light (daylight) level is under the set value brightness, and the detector registers a movement (1), the light switches on (configurable, here in the example to 100%).

Then, using the brightness level determined (2), the light is regulated until the set value is reached. From now on, the detector regulates the light (3) and keeps the room brightness at a constant value (set value), until the proportion of artificial light reaches 0% (4).

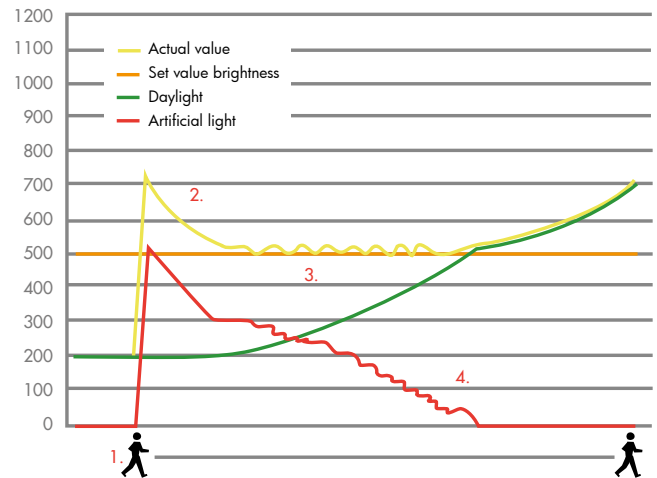

## 2.7 Detector functional groups

The occupancy detector has five outputs: the light output (A1), the HVAC outputs (A2 to A4) and the slave output (SL). To enable the automatic switching/regulating functions to be realised, all outputs access the sensors. The light measurement is set the same way for all the outputs, but each output can have its own switch-on threshold and a set value can be defined for the light output A1 in regulation mode. The sensitivity of the motion and sound detection can be adjusted for every output. The most important output is the light output (A1). In this group, the basic function of the occupancy detector is performed. The slave output (SL) expands the detection area. In addition, three HVAC outputs (heating, ventilation and air conditioning) are available. These outputs are for the control of energy-intensive systems such as air conditioning. Additional functions can be configured in the relevant group. The scope of the additional functions depends on the detector variant (see section 1) and the detector type used. The division of the group is shown in the structure of the ETS parameter tree.

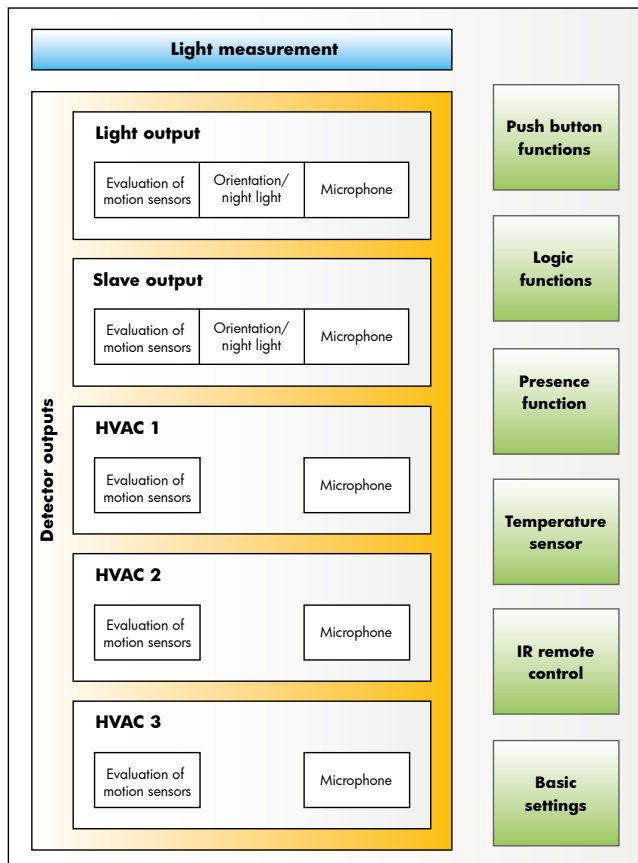

With the application, the functions that are required can be activated individually for each output. In the first configuration step, it must be determined which and how many outputs are required and these must be activated in ETS.

Commonly, the light is to be regulated in a room depending on the daylight and the presence of persons. This requires the light output A1. The room also contains further HVAC (heating, ventilation and air conditioning) devices that are also to be automatically switched on by a detector. Depending on the number of devices, the HVAC outputs A2 to A4 must be connected for this purpose. Depending on the size of the room, a slave device may be necessary (see section 15), which is controlled via the slave output (SL).

## 2.8 Detector modes

The light output can operate as an occupancy detector or a twilight detector. If the measured light value is below the preset value, the twilight detector switches the light on regardless of whether or not there is movement; an occupancy detector, on the other hand, operates based on motion.

Occupancy and twilight detector can switch as well as regulate (see section 2.6). The HVAC outputs can only be operated in switching mode.

In offset switching mode, the light output can switch up to three lighting runs with the aid of an offset value. The lighting run that is furthest away from the window serves as the basis for the light regulation. This means that as the daylight increases, the lighting run that is on the window side is the first to be switched off (see section 10).

Semi- or full automatic operation can be selected individually for the light output and the HVAC outputs. It is also possible to change the operating mode after ETS programming is complete. A group object and/or IR remote control can be used to switch between operating modes (see section 5.1.1).

When the slave output is activated, a "1" telegram is sent via group object 25 "slave output" when movement is detected, which is received by

the master device via group object 30 "slave input". The master device determines whether the light should be switched on (see section 15).

## 2.9 Light output (A1)

The light output A1 (block) contains all the functions of an occupancy detector. It is used to automatically switch or regulate the light depending on the ambient brightness and on whether movement is detected.

Detector outputs	
Light output A1	<b>deactivated</b>
	Occupancy detector
	Twilight detector
Operation mode	<b>Switching mode</b>
	Offset switching mode
	Regulation mode

A1: Occupancy detector (switch/regulate)	
Operation mode of the detector	<b>Full automatic mode</b>
	Semi-automatic mode
Operation mode changeable	<b>deactivated</b>
	via group object
	via remote control
	via group object and remote control
Modified operation mode by ETS download	<b>overwritable</b>
<i>(only visible for group object or remote control)</i>	not overwritable

The ETS programming is overwritten.

No.	Name	Function	C	R	W	T	U
41	A1: Input (DPT 1.002)	Switch mode VA=1 HA=0	C	-	W	-	-

## 2.10. HVAC outputs A2 to A4

These outputs are optimised for HVAC applications (heating, ventilation, air conditioning). Only one switching mode and no regulation mode is possible here (see section 16).

Detector outputs	
HVAC outputs A2 (to A4)	<b>deactivated</b>
	activated

A2 (to A4): HVAC	
Operation mode of the detector	<b>Full automatic</b>
	Semi-automatic
Operation mode changeable	<b>deactivated</b>
	via group object
	via remote control
	via group object and remote control

A2 (to A4): HVAC	
Modified operation mode by ETS download <i>(only visible for group object or remote control)</i>	<b>overwritable</b>
	not overwritable

The ETS programming is overwritten.

No.	Name	Function	C	R	W	T	U
67	A2: Input (DPT 1.002)	Change operat. mode VA=1 HA=0	C	-	W	-	-
82	A3: Input (DPT 1.002)	Change operat. mode VA=1 HA=0	C	-	W	-	-
97	A4: Input (DPT 1.002)	Change operat. mode VA=1 HA=0	C	-	W	-	-

### 2.11 Slave output

This output is required in order to establish a master-slave system. If a large room is to be monitored, the detection area can be increased by any size through the use of slave devices (see section 15).

Detector outputs	
Slave output (SL)	<b>deactivated</b>
	activated

No.	Name	Function	C	R	W	T	U
13	SL: Input (DPT 1.002)	Reset	C	-	W	-	-
25	SL: Output (DPT 1.002)	Slave (SL)	C	-	-	T	-

The slave output is automatically available for the HVAC outputs.

No.	Name	Function	C	R	W	T	U
63	A2: Input (DPT 1.002)	Slave (SL)	C	-	W	-	-
78	A3: Input (DPT 1.002)	Slave (SL)	C	-	W	-	-
93	A4: Input (DPT 1.002)	Slave (SL)	C	-	W	-	-

### 3. Basic settings of the detector

In the basic settings, certain additional functions can be activated or settings configured that apply to the detector as a whole. Specifically, this includes the following functions:

- Start delay for the detector (section 3.1)
- Test mode (section 3.2)
- LED indicators (section 3.3)
- Sound sensor (section 3.4)
- Temperature measurement (section 3.5)
- IR remote controls (section 3.6)
- Regulation step via remote control as a percentage (section 3.7)
- IR PIN (section 3.8)

#### 3.1 Start delay for the detector

When the KNX bus is switched on (power is returned to the bus), all the participants connected on one line are immediately ready for operation. If there are several sensors in a line that want to send initialisation or start telegrams, it is possible for the telegram load to be too high when power is returned to the bus and for telegrams to potentially go missing.

This switch-on behaviour can be avoided by using the start delay. The detector only sends its first telegrams once the start delay has elapsed. Start delays of different lengths should be set for the sensors/detectors within a line.

Basic settings	
Start delay in seconds	<b>0 – 255 [0]</b>

#### 3.2 Test mode

Test mode is for checking the detection area. If movement is detected, the lighting switches on for 2 seconds and then off again. The duration until the next switch-on depends on the length that was set up for the safety delay.

Test mode can be activated as follows:



- with a 1-bit "1" telegram on the group object 0 "General: Input – Test mode",
- with the "Test" button on the remote control,
- both with a group object and with the remote control.

Test mode is deactivated:



- automatically after 3 minutes,
- after the "Reset" button on the remote control is operated,
- with a 1-bit "0" telegram on the group object 0 – "General: Input – Test mode"

Basic settings	
Test mode	<b>deactivated</b>
	via group object
	via remote control
	via group object and remote control

No.	Name	Function	C	R	W	T	U
0	General: Input (DPT 1.001)	Test mode	C	-	W	-	-

#### 3.3 LED indicators

Since the integrated LEDs (for motion/IR/sound sensor; red) can be perceived as a source of disturbance in some locations, for example in the bedroom, there is an option to switch them off after programming with ETS.

If the option to flexibly switch the LED indicators (motion/IR/sound sensor LEDs) on and off with ETS after commissioning is desired, this must be enabled in ETS. The LED for motion detection and IR can be switched off and on as follows:



- via the corresponding group object, where a 1-bit "0" telegram switches the LED off and a 1-bit "1" telegram switches it on
- with the "LED off" and "LED on" buttons on the remote control,
- both with the group object and with the remote control.

The same applies for the sound sensor (see section 3.4).

Basic settings	
Motion/IR LED	<b>deactivated</b>
	activated
Activation modificable	<b>deactivated</b>
	via group object
	via remote control
	via group object and remote control

No.	Name	Function	C	R	W	T	U
2	General: Input (DPT 1.001)	Activation motion/IR LED	C	-	W	-	-

### 3.4 Sound sensor

Some detectors have a built-in sound sensor. This detects sounds and is used in rooms that are not fully visible to the detector, such as wash-rooms with individual cubicles. Sound detection is only activated once the detector has detected a movement via the passive infrared sensor ((1) & (2)). The sound sensor is then active and the follow-up time of the detector is restarted according to the movements and sounds detected. After the light has been automatically switched off, the sound sensor remains active for a limited detection period (waiting period) (3) so that the light can be reactivated by sounds even after it has been switched off. The duration of the waiting period is freely selectable.

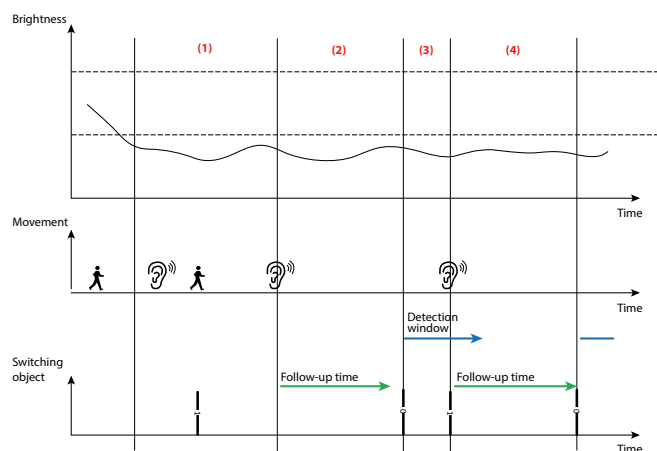

An LED (red) lights up as soon as the sound sensor detects a sound. It is also possible to configure this LED so that it can be deactivated during operation, via a group object or via the bidirectional smartphone app (see section 17).

Depending on the settings, the sensitivity can be adjusted in ETS by means of a potentiometer on the detector or via the bidirectional smartphone app. If the smartphone app is used, a standard value for the sensitivity (start value) can be configured in ETS. If the sensitivity is adjusted via the smartphone app, this may be overwritten by a new ETS download (configurable).

Basic settings	
LED sound sensor (note device variant)	<b>deactivated</b>
	<b>activated</b>

Basic settings	
Activation modificable	<b>deactivated</b>
	via group object
	via remote control
	via group object and remote control
Modified operation mode by ETS download	<b>overwritable</b>
<i>(only visible for group object or remote control)</i>	not overwritable
Sound sensor sensitivity	<b>modification via potentiometer</b>
	modification via remote control

Basic settings	
<b>Sound sensor</b>	
<i>(only visible if remote control enabled)</i>	
Sensitivity	10 sensitive
	<b>9</b>
	8
	...
	2
	1 insensitive
	0 deactivated
Sound sensor sensitivity	<b>modification via remote control</b>
Modified operation mode by ETS download	<b>overwritable</b>
<i>(only visible for group object or remote control)</i>	not overwritable

No.	Name	Function	C	R	W	T	U
3	General: Input (DPT 1.001)	Activation LED sound sensor	C	-	W	-	-

To obtain signals from the sound sensor, sound detection must be switched on at the individual outputs (additional function). The example below shows this for the light output A1.

The sound sensor can be deactivated/activated during operation. This can be done via group object or the bidirectional smartphone app. Parameters can be used to decide whether a selection that has been modified in this way is overwritten by ETS at the next download.

The functioning of the detector can be influenced by the connection of actuators that are located in the detection area of the sound sensor. For example, the occupancy detector automatically switches the light back on if the noise the actuator makes when switching off can be heard. To eliminate this effect, a safety delay (2) can be started, which suppresses repeat switching-on between the end of the follow-up time and the detection window.

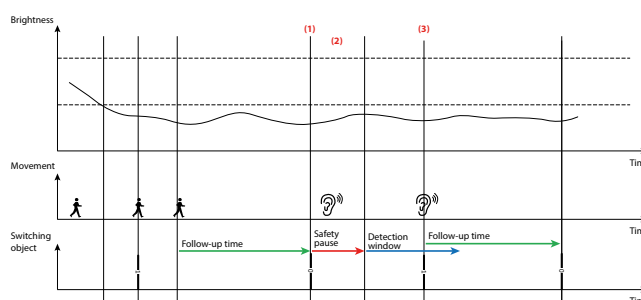



<b>A1: Occupancy detector</b>	
<b>Additional functions</b>	
Sound sensor (NOTE DEVICE VARIANT!)	<b>deactivated</b>
	activated

<b>A1: Occupancy detector</b>	
<b>Additional functions</b>	
<b>Sound sensor</b>	
Sound sensor	<b>released</b>
	locked
Activation modifiable	<b>deactivated</b>
	via group object
	via remote control
	via group object and remote control
Modified activation by ETS download <i>(only visible for group object or remote control)</i>	<b>overwritable</b>
	not overwritable
Waiting period in seconds	0 – 255 [10]
Safety delay in seconds	0 – 255 [1]

No.	Name	Function	C	R	W	T	U
42	A1: Input (DPT 1.001)	Activate sound sensor	C	-	W	-	-
68	A2: Input (DPT 1.001)	Activate sound sensor	C	-	W	-	-
83	A3: Input (DPT 1.001)	Activate sound sensor	C	-	W	-	-
98	A4: Input (DPT 1.001)	Activate sound sensor	C	-	W	-	-
14	SL: Input (DPT 1.001)	Activate sound sensor	C	-	W	-	-

### 3.5. Temperature measurement

In order to enable use of the temperature sensor that is integrated in certain detectors, temperature measurement must be activated in the basic settings. Further parameters are displayed in an additional ETS menu.

The temperature of the ceiling is different to that of the workplace. This difference can be compensated for by an offset value. The offset value is determined using a temperature measurement at the ceiling and one at the workplace.

The following factors can diminish the quality of the temperature measurement:

-  - In suspended ceilings, the air circulates frequently. Draughts may occur e.g. when a door is opened. Partition walls between offices may not be solid, for example, so that the air circulates in the suspended ceiling.
- Flat roofs are heated up by the sun's rays. The space between the roof and the suspended ceiling has a higher temperature than the space below the suspended ceiling. Because the detector is positioned directly between them, draughts may occur here.
- LEDs integrated in the detector may cause the device to heat up.

The temperature can be sent to the bus if it changes. The level from which the change is sent can be selected. The value can also be sent cyclically. The cycle time can be set to anywhere from 1 second to 1 hour.

<b>Basic settings</b>	
Temperature measurement	<b>deactivated</b>
	activated

<b>Basic settings</b>	
<b>Temperature measurement</b>	
<i>(only visible if temperature measurement is activated)</i>	
Correction value in 0.1 K	-128 – 127 [0]
Send temperature	<b>deactivated</b>
	upon modification
	cyclically
	upon modification and cyclically
Cycle time in minutes <i>(only visible for sending cyclically)</i>	0 – 59 [0]
Cycle time in seconds <i>(only visible for sending cyclically)</i>	0 – 59 [5]
Change in 0.1 K <i>(only visible in the event of change)</i>	0 – 10 [5]

No.	Name	Function	C	R	W	T	U
11	Temperature sensor: Output (DPT 9.001)	Temperature	C	-	-	T	-

### 3.6 IR remote controls

For improved convenience, settings can be configured via the bidirectional smartphone app or IR remote controls. A distinction is made here between the remote control IR-PD-KNX (92123) with 27 buttons for configuration and the end-customer remote control IR-PD-KNX-Mini (93398) with 5 buttons, which is additionally available for the DX variant. The remote control capability is described in more detail in section 17.

<b>Basic settings</b>	
Type of remote control	<b>5 buttons (freely programmable)</b>
	27 buttons (configuration)

### 3.7 Regulation via remote control as a percentage

(see section 17.3.6)

### 3.8 IR PIN

In order to safeguard the detector against undesired changes to the settings, there is the option to secure it with a PIN. A four-digit identification number (0-9999) can be set under the "IR PIN" parameter, where no PIN is used if "0" is entered.

This PIN can optionally be overwritten via ETS download (see section 17.3.1).

## 4. Light measurement

### 4.1 Basic principles

A detector conducts light measurement at the ceiling of the room, because this is where it is installed. This means that it measures light which is present in the room as sunlight and artificial light and is reflected onto the ceiling. However, not all the light is reflected, as the reflection factor depends greatly on the surfaces and furnishings. The light value measured on the ceiling does not therefore represent the room bright-

ness. Therefore, the reflection factor must be determined, and the KNX occupancy detector adjusted to local conditions.

#### 4.2 Reflection factor

The occupancy detector measures the light that is reflected from the floor, work surface or walls. The reflection factor is the ratio between the brightness measured at the ceiling and that measured at the work surface. This gives a reflection factor, which is between 1:2 and 1:3 in normal room conditions. When calculating the reflection factor, the ratio of artificial light to daylight is also considered. As the spectrum of daylight is greater than that of artificial light, the latter is calculated with a ratio of 1:4 as standard and the former with a ratio of 1:2.

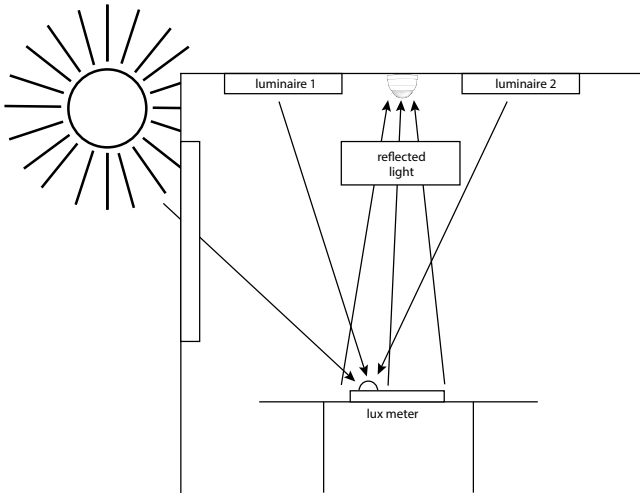

Depending on the device, the detector may have up to two light sensors. In detectors with two light sensors, sensor 1 is located in the outer ring and sensor 2 behind the lens. In detectors with only one light sensor, the sensor behind the lens is sensor 1. The light sensor located behind the lens measures the light from the entire room (average value), while the sensor in the outer ring of the detector takes more localised measurements.

A group object is also available. In this way, for example, the light value of a slave device can be used at a different location in the room.

#### 4.3 Types of light measurement

In addition to communication with the B.E.G. lux meter IR-LM via infrared, the detector has up to three sources at its disposal for light measurement:

- (1) Light sensor 1: This light sensor is located in the outer ring in detectors with two light sensors and behind the lens in detectors with one light sensor.
- (2) Light sensor 2: This light sensor is located behind the lens in detectors with two light sensors.
- (3) Group object 7 (Light sensor: Input: Brightness): This enables external light sensors to be connected.

Two types of light measurement are available. Either the smallest light value is determined from up to three sources, or the three sources can be weighted against one another.

Light measurement	
Use of the smallest measured light value (from up to 3 sources)	<b>deactivated</b>
	activated

**!** Depending on the detector type and variant, up to two light sensors are integrated in the detector and the brightness object is available. Only when the corresponding source is available does the respective parameter have the described function.

#### 4.3.1 Weighted measurement

For devices with more than one light sensor, the weighting between sensor 1, sensor 2 and group object 7 "Light sensor: Input: Brightness" (sources) can be configured. This counteracts the effects of the different sensors having different levels of influence. The weighting of the various light sensors plays a role in rooms where the lighting is poor. If, for example, the internal light sensor is used, this has an extreme reaction to changing lighting conditions, because it gets a mixed value for the light from the entire room. The optional light sensor in the outer ring takes a more localised measurement and is therefore less sensitive to external influences. However, a change in the lighting situation in the direct vicinity of the measurement point is problematic. If the detector is mounted above the desk, for example, which has a dark workspace, a white sheet of paper can lead to a change in the lighting situation which can cause the detector to dim the light. The weighting of the sensors can mitigate these influences.

**!** If a detector type or variant does not support a source, a "0" (= not available) must be entered in ETS for this source.

Light measurement	
Weighting of light sensor 1 (0 = is not used) <i>(only visible for deactivated use of the smallest measured light value (from up to 3 sources))</i>	0 – 10 [1]
Weighting of light sensor 2 (DEVICE VARIANTS WITH TWO SENSORS) <i>(only visible for deactivated use of the smallest measured light value (from up to 3 sources))</i>	0 – 10 [0]
Weighting of group object brightness (0 = is not used) <i>(only visible for deactivated use of the smallest measured light value (from up to 3 sources))</i>	0 – 10 [0]

#### 4.3.2 Smallest measured light value

If a room has two window facades opposite each other, the darkest point of the room will move from one window facade to the other over the course of the day. Because the light measurement is always taken on the basis of the darkest point of the room, it is recommended in this case to install a master-slave system or a detector with an additional external brightness sensor.

If the master device is on the shady side in the morning, with the slave device on the sunny side at the same point in time, the master device uses its own brightness value when measuring. It also compares its own measured light value with the value measured by the slave device. As soon as the measured brightness value of the slave device is lower than that of the master device due to the sun's changing position, it is then used as the basis for the light control. Measurement of the brightness value at the darkest point is therefore guaranteed even in changing lighting conditions.

⚠ If a detector type or variant does not support a source, a "0" (= not available) must be entered in ETS for this source.

⚠ If a slave device is connected to a master device via group object "Brightness", the parameter "Adjustment of the measured value using external values" (light measurement) must be deactivated. If it is not deactivated, the slave device takes into consideration its own reflection factor. This calculated value is then re-evaluated by the master device in its calculation, so that as a result the light value is double calculated and wrong.

Light measurement	
Light sensor 1 <i>(only visible for activated use of the smallest measured light value (from up to 3 sources))</i>	use
	do not use
Light sensor 2 (DEVICE VARIANTS WITH TWO SENSORS!) <i>(only visible for activated use of the smallest measured light value (from up to 3 sources))</i>	use
	do not use
Group object brightness <i>(only visible for activated use of the smallest measured light value (from up to 3 sources))</i>	use
	do not use

The group object "Brightness" is monitored by the application. If the external light sensor fails, it is removed from the measurement and light sensor 1 automatically takes over measurement. The monitoring is based on the configured monitoring time. The detector obtains the light value for the slave device "cyclically" or "upon modification" depending on the settings (see section 4.4).

**Note:** The send cycle of the slave device must be within the monitoring time of the master device

Light measurement	
Group object brightness	use
	do not use
Read out group object brightness on bus voltage return <i>(visible for "use")</i>	activated
	deactivated
Monitor group object brightness <i>(visible for "use")</i>	activated
	deactivated
Monitoring time in minutes <i>(visible for monitoring)</i>	1 – 255 [10]

No.	Name	Function	C	R	W	T	U
7	Light sensor: Input	Brightness	C	-	W	T	U

#### 4.3.3 Adjusting the measured value using the B.E.G. infrared lux meter IR-LM (item no. 93030)

If the brightness at the workplace is determined via a brightness measurement at the ceiling and a reflection factor, measuring inaccuracies always occur. The optional B.E.G. lux meter IR-LM (accessory, item no. 93030) can significantly improve the measurement.

The B.E.G. IR lux meter IR-LM is placed on the workplace (the detector must be in the line of sight). Therefore, it always takes its measurements

where the set value brightness should be. It sends infrared signals with the measured brightness value to the detector.

The B.E.G. IR lux meter IR-LM can optionally be used as follows:

#### Receive permanently

In this mode, the B.E.G. IR lux meter IR-LM sends the measured brightness to the detector. The detector then dynamically calculates a reflection factor from this value, and thus constantly adapts the factor to the present situation. If the B.E.G. IR lux meter IR-LM fails, the detector takes the most recent valid value. In this case, the motion LED of the detector flashes to indicate that it is no longer receiving a signal via IR.

#### 24-hour learning phase

The learning phase can be activated/deactivated using a group object and/or via remote control. The B.E.G. IR lux meter IR-LM only remains on the workplace for the corresponding period in this case, and the detector stores the measured light curve over the time period and uses this as the basis for light regulation.

An additional correction value of +/-200 lux can also be input in the event of inaccuracies.

Light measurement	
Determination of the reflection factor via IR receiver	activated
	deactivated
Measured light values will be received via IR receiver <i>(visible for activation)</i>	permanently
	during the 24h learning phase
Correction value in lux <i>(visible for activation)</i>	-200 – 200 [0]

Light measurement	
Learning phase modifiable <i>(visible for use of the 24-hour learning phase)</i>	via group object
	via remote control
	via group object and remote control

No.	Name	Function	C	R	W	T	U
8	Light sensor: Input (DPT 1.010)	Learning start/stop	K	-	S	-	-

#### 4.3.4 Adjustment of the measured value using external values

A distinction is made between "mixed light" and "artificial light and daylight" (see section 4.3). The parameter can also be deactivated. If the parameter is activated, values that are measured under the ceiling and on the work surface can be input manually.

The brightness value on the workplace and at the detector must be measured. Accordingly, two values must be measured in the "mixed light" setting and four values in the "artificial light and daylight" setting.

#### Artificial light:

For this measurement, only the light that has been switched on should be present. Natural light must not enter the room. A measurement can therefore only be taken at night or with the blinds closed.

#### Daylight:

Here, the measurement must be taken with the natural light that enters the room only. All lights in the room must be switched off.

### Mixed light:

The measurements are taken with the lights switched on (the lights that the detector is to switch/regulate) and the natural light entering the room.

If this setting is deactivated, a reflection factor of 1:1 is assumed. An additional correction value of +/-200 lux can also be input in the event of inaccuracies.

**i** In order to achieve optimum results with the light regulation, the setting "artificial light and daylight" is recommended.

### Method:

#### For the "mixed light" setting:

##### Step 1:

The parameter "Adjustment of the measured value using external values" must first be deactivated so that the measured light value of the detector is output on the bus. The brightness value should be sent cyclically. (see section 4.4)

##### Step 2:

Open the blinds, switch on the lights.  
Note the light value of the detector below the ceiling.  
Note the light value of the lux meter on the work surface.

##### Step 3:

Activate the parameter "Adjustment of the measured value using external values" and enter the measured values.

#### For the "Artificial light and daylight" setting

##### Step 1:

The parameter "Adjustment of the measured value using external values" must first be deactivated so that the measured light value of the detector is output on the bus.

##### Step 2:

Close the blinds, switch on the lights.  
Note the light value of the detector below the ceiling.  
Note the light value of the lux meter on the work surface.

##### Step 3:

Open the blinds, switch off the lights.  
Note the light value of the detector below the ceiling.  
Note the light value of the lux meter on the work surface.

Activate the parameter "Adjustment of the measured value using external values" and enter the measured values.

After entering the corresponding light values, the calculated light value is output on the bus. The value of the lux meter on the work surface should now be similar to the value output on the bus.

Light measurement	
Determination of the reflection factor via IR receiver	activated
	deactivated

Light measurement	
Adjustment of the measured value using external values <i>(visible when "Determination of the reflection factor via IR receiver" deactivated)</i>	deactivated
	Mixed light
	Artificial light and daylight
Artificial light - measured value ceiling in Lux <i>(visible when "Determination of the reflection factor via IR receiver" deactivated)</i>	1 – 2000 [100]
Artificial light – measured value desk in lux <i>(visible when "Determination of the reflection factor via IR receiver" deactivated)</i>	1 – 2000 [400]
Daylight - measured value ceiling in Lux <i>(visible when "Determination of the reflection factor via IR receiver" deactivated)</i>	1 – 2000 [100]
Daylight – measured value desk in Lux <i>(visible when "Determination of the reflection factor via IR receiver" deactivated)</i>	1 – 2000 [200]
Correction value in Lux <i>(visible when "Determination of the reflection factor via IR receiver" deactivated)</i>	-200 – 200 [0]

If the "mixed light" parameter is selected, the values for natural light are not recorded.

### 4.4 Send brightness value

The measured brightness value can be used for light measurement via the external brightness object using the parameter "send brightness value". This object is available for both master and slave devices. The measured light value is sent in the "off" mode. In the "on" mode, it is only sent once the switch-off threshold has been determined or if the "mixed light" setting is active so as to obtain the exact value.

Light measurement	
Send brightness value	deactivated
	upon modification
	cyclically
	upon modification and cyclically
Modification in Lux <i>(sichtbar bei „Änderung“)</i>	1 – 200 [10]
Cycle time in minutes <i>(visible for "send cyclically")</i>	0 – 59 [0]
Cycle time in seconds	0 – 59 [5]

No	Name	Function	K	L	S	Ü	A
9	Light sensor: Output (DPT 9.004)	Brightness	C	-	-	T	-

## 5. Detector outputs

In the menu “Detector outputs”, different outputs can be selected depending on the application. The light output A1 is available as an occupancy or twilight detector. Depending on the operating mode, the user can choose between switching, offset switching and regulation mode. Outputs A2 to A4 are available as HVAC channels. These are defined as brightness-independent switching channels in the standard settings, but can also be used for light-dependent switching when movement is detected through configuration of the appropriate settings.

### 5.1 Occupancy detector (switching)

If the light output is operated as an occupancy detector, the lighting is switched on depending on the movement and the brightness threshold and is switched off again once the follow-up time has elapsed, as long as no new movement was detected during this time.

This light can also be switched on or off manually (see section 5.3.1). If it is switched off manually, it remains switched off if movement is detected during the follow-up time (projector function). If the follow-up time elapses without movement being detected, the detector returns to the configured mode.

#### 5.1.1 Operating modes

Here, the user can first decide whether the device is to operate in semi- or full automatic mode.

#### Full automatic mode

In this mode, the lighting switches on and off automatically, according to occupancy and brightness, for greater convenience.

#### Semi-automatic mode

In this mode, the lighting only switches on by manual operation, for improved energy saving. Switching off takes place automatically or manually. Once the follow-up time has elapsed, the light can be automatically reactivated by movement within the period defined as the waiting period. After this time has elapsed, the push button must be pressed again to switch on the light.

The operating mode can be changed without ETS. If a “1” telegram is sent, the detector operates in full automatic mode; if a “0” telegram is sent, it operates in semi-automatic mode.

Modified operation mode by ETS download <i>(only visible for group object or remote control)</i>	<b>overwritable</b>
	not overwritable

#### The ETS programming is overwritten.

No	Name	Function	C	R	W	T	U
41	A1: Input (DPT 1.002)	Change operat. mode VA=1 HA=0	C	-	W	-	-

### 5.2 Twilight detector

If the light output is set to twilight detector, the device switches on the lighting if the brightness level drops below the configured brightness value and switches it off again when this value is exceeded. The channel therefore reacts not to movement but only to brightness. The twilight detector can be activated/deactivated via a button. If the function is activated, the device operates during the day, for example, whereas it is not required at night and can therefore be deactivated. This can be useful in production halls, for example, where work is only carried

out during the day but the lights must be switched on as soon as the lighting level drops below a specified value.

Detector outputs	
A1 Light output	deactivated
	<b>Occupancy detector</b>
	Twilight detector

Light output	
Operation mode	<b>Switching mode</b>
	Offset switching mode
	Regulation mode

HVAC outputs	
A2	<b>deactivated</b>
	activated
A3	<b>deactivated</b>
	activated
A4	<b>deactivated</b>
	activated

Slave output	
Slave (SL)	<b>deactivated</b>
	activated

### 5.3 A1: Light output (operation mode switching)

The channel A1 “Light output” is the main channel of the detector and can optionally be used as an occupancy or twilight detector.

#### 5.3.1 Manual influence

Using manual control, the channel can be switched on or off manually with the aid of a button. The channel remains switched on or off as long as no movement is detected during the follow-up time.

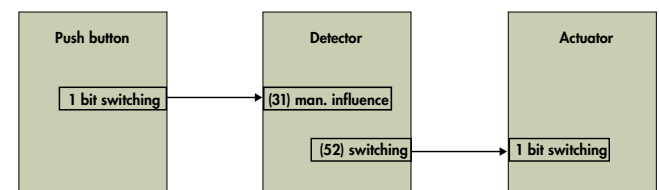

No	Name	Function	C	R	W	T	U
31	A1: Input (DPT 1.001)	Manual influence	C	-	W	-	-
52	A1: Output (DPT 1.001)	Switching	C	-	-	T	-

The following group objects are also available in the occupancy detector mode:

No	Name	Function	C	R	W	T	U
30	A1: Input (DPT 1.002)	Slave (SL)	C	-	W	-	-
61	A1: Output (DPT 1.002)	Reset	C	-	-	T	-

## 6. Follow-up time

**i** The follow-up time defines the duration during which the connected load remains switched on even if no more movements have been detected. If a new movement is detected during the follow-up time, it is restarted.

### 6.1 Setting the follow-up time

The "Follow-up time" menu provides options for determining the duration as well as the type of triggering.

<b>Follow-up time</b>	
in seconds	0 ... 59 (0)

<b>Follow-up time</b>	
in minutes	0 ... 59 (10)

<b>Follow-up time</b>	
in hours	0 ... 23 (0)

### 6.2 Overwrite follow-up time

The follow-up time can be changed without ETS by way of a group object, where it is specified in the format "minutes".

The modified operating mode can optionally be overwritten by ETS download.

<b>Follow-up time</b>	
Follow-up time overwritable	<b>deactivated</b>
	via group object
	via remote control
	via group object and remote

Modified follow-up time by ETS download	<b>overwritable</b>
<i>(only visible for group object or remote control)</i>	not overwritable

The ETS programming is overwritten.

No	Name	Function	C	R	W	T	U
35	A1: Input (DPT 7.006)	Follow-up time	C	-	S	-	-

### 6.3 Triggering

Here it is determined when triggering should take place:

- Immediately upon detected movement  
The telegram is sent immediately when movement is detected and the brightness value drops below the threshold.
- After observation time  
If this option is chosen, further parameters become visible. One observation time and a number of observation windows can be defined. At least one movement must be detected in each window to allow the channel to switch on.  
Example: Three monitoring windows each with a monitoring time of 10 seconds.  
After the first detected movement (A), the detector starts window 1. If no movement is detected during the observation time, the evaluation is ended. If at least one movement (B) is detected during the window, after the first window (C) has elapsed, the second observation window is started. Here too, evaluation is terminated if no movement is detected

within the duration of the window. If at least one movement is detected (D), the third window is started (E). If more than three windows are set in the parameters, this is repeated for the total number of observation windows. The detector switches on, as soon as the last window has detected its first movement (F). So in this example, this will result in a delay time of 21-30 seconds (depending on when the last movement is detected). If there is no movement in a window, all windows are reset.

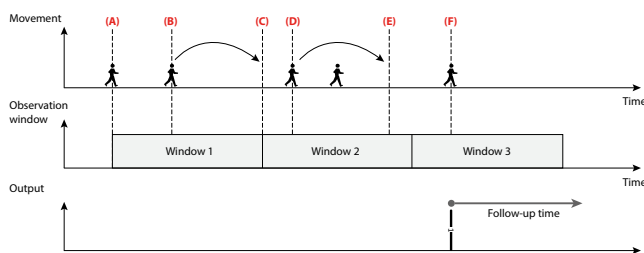

<b>Follow-up time</b>	
Triggering	immediately upon detected movement
	after observation time

### 6.4 Waiting period at the end of the follow-up time in semi-automatic mode

This parameter only relates to semi-automatic mode and enables the lighting to be automatically switched back on within a defined period after the follow-up time has elapsed and the light has thus been switched off. A waiting period can be set as the duration, or the duration of the orientation light (of the internal LEDs) can be used.

<b>Follow-up time</b>	
Waiting period after follow-up time in semi-automatic mode in minutes	Duration of the orientation light (LED)
	Duration of the reaction window

<b>Follow-up time</b>	
Waiting period in seconds	0 ... 255 (10)

### 6.5 Individual follow-up times of the sensors (NOTE DEVICE VARIANT)

If this parameter is activated, then – taking into account the device variant – for detectors with more than one motion sensor (3 or 4 sensors), a separate, percentage share of the follow-up time can be set for each sensor.

#### Usage example:

RC-plus next 230 KNX with two sensors for remote detection and one for creep protection, mounted above the front door

Follow-up time for sensor 1 (short route to front door, left): 50 %

Follow-up time for sensor 2 (long route to house, right): 100 %

Follow-up time for sensor 3 (anti-creep zone, region of the front door itself): 25 %

Configured follow-up time: 4 minutes

**i** If a person leaves the house, they are first detected by the sensor of the anti-creep zone and then by the corresponding sensor for remote detection, in this case sensor 2. The follow-up time configured for sensor 2 (100% of 4 minutes) therefore runs down, as the

person was last recorded here. This can increase the safety of persons located outdoors. (Figure A)

If the person enters the house, they are first detected by one of the sensors for remote detection and then by sensor 3 for the anti-creep zone. In this case, therefore, the follow-up time configured for sensor 3 (25% of 4 minutes) runs down and energy can be saved. (Figure B)

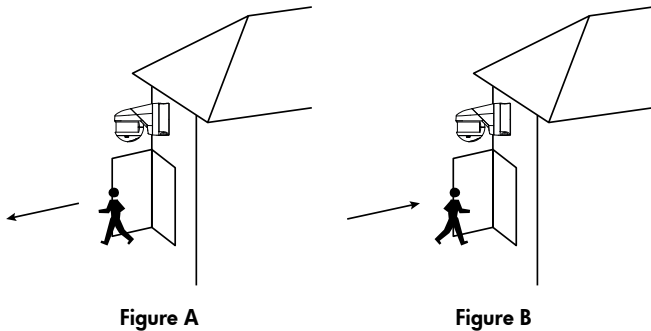

Follow-up time	
Individual follow-up time of the sensors (NOTE DEVICE VARIANT)	<b>deactivated</b>
	activated

Follow-up time	
Proportion of the follow-up time for sensor x in percent <i>(visible for activation)</i>	<b>100</b>
	50
	25
	12.5

## 7. Switch-on threshold

In the "Switch-on threshold" menu, settings can be configured that relate to the automatic switching on and off of the lights. The brightness value set here becomes the switch-on threshold. If the brightness level drops below this threshold and the detector detects movement, the lights are switched on.

### 7.1 Adjust switch-on threshold

The user can first select whether the lights are to be switched on depending on the brightness. If this parameter is activated, the input brightness value becomes the switch-on threshold.

Switch-on threshold	
in Lux	5 ... 2000 ( <b>500</b> )

### 7.2 Overwrite switch-on threshold

The switch-on threshold can be overwritten without ETS if required via a group object and/or remote control.

The brightness threshold modified here can be overwritten via ETS download if required.

Switch-on threshold	
Switch-on threshold overwritable	<b>deactivated</b>
	via group object
	via remote control
	via group object and remote control

Modified switch-on threshold by ETS download <i>(only visible for group object or remote control)</i>	overwritable
	not overwritable

The ETS programming is overwritten.

No	Name	Function	C	R	W	T	U
36	A1: Input (DPT 9.004)	Threshold 1	C	-	W	-	-

### 7.3 Additional threshold

If a second brightness threshold is required, a second brightness value can be input here. It is possible to switch between the two values at any time. Here, threshold 1 is active for a "0" telegram and threshold 2 for a "1" telegram.

Switch-on threshold	
Additional threshold	deactivated
	activated

Switch-on threshold	
Switch-on threshold 2 in Lux <i>(visible for activation)</i>	5 ... 2000 (1200)

No	Name	Function	C	R	W	T	U
37	A1: Input (DPT 1.002)	Change threshold S1=0, S2=1	C	-	W	-	-

### 7.4 Calculation of the switch-off threshold

Here, the duration is determined in which the switch-off threshold is calculated. The duration depends on the lights connected, which should have reached their full brightness before the end of the measurement process so that the correct stroke between switched-on and switched-off lighting can be measured.

The hysteresis of the switch-off threshold is a tolerance value that must be taken into account in the calculation in order to prevent the lighting being switched back on due to the change in lighting caused by the switching off.

The daylight-dependent switch-off delay is the duration during which the detector recognises that the switch-on threshold has been permanently exceeded due to sufficient daylight. Once the duration has expired, the detector switches off the lights even if movement is detected.

Switch-on threshold	
Calculation of the switch-off threshold in minutes	1 ... 10 ( <b>2</b> )

Switch-on threshold	
Hysteresis of the switch-off threshold in lux	50 ... 255 ( <b>100</b> )

Switch-on threshold	
Daylight-dependent switch-off delay in minutes	1 ... 60 (10)

### 7.5 Waiting period after daylight-dependent switch-off in semi-automatic mode

This parameter only relates to semi-automatic mode (see section 5.1) and has the effect that the detector can switch the lights back on after switching them off due to increasing daylight if movement is detected and the brightness level once again drops below the threshold. The configured follow-up time is used as the basis for this.

Switch-on threshold	
Waiting period after daylight-dependent switch-off in semi-automatic mode	deactivated
	activated

## 8. Switching output

The "Switching output" menu defines what the detector sends as soon as a triggering has taken place and what is sent after the follow-up time has elapsed.

The following configuration options are available:

Switching output	
Detector sends	Switching object
	Value object
	Switching and value object
	Scene number

Depending on the settings, the selection options may be different for the "Value" parameter. This applies both for the reaction upon triggering and the reaction after expiry of the follow-up time.

### 8.1 Switching object

If "Switching object" is selected, the user can choose between a "0" and "1" telegram.

Switching output	
Telegram upon triggering	is sent
Value	1 ... 0 (1)
Telegram at end of follow-up time	is sent
Value	1 ... 0 (0)

No	Name	Function	C	R	W	T	U
52	A1: Output (DPT 1.001)	Switching	C	-	-	T	-

### 8.2 Value object

If "Value object" is selected, a value between 0 and 100% can be selected. This value is sent to the actuator.

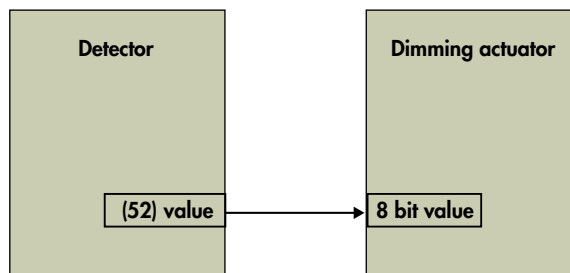

No	Name	Function	C	R	W	T	U
52	A1: Output (DPT 5.001)	Value	C	-	-	T	-

### 8.3 Switching and value object

With this option, for example, the lighting can be regulated via the value object and the status (on/off) can be sent to the actuator via the switching object. The value of the value object can be modified via group object "trigger value" (object 43).

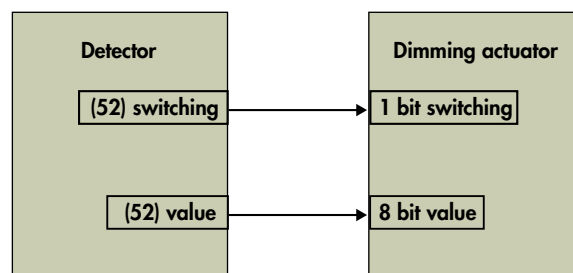

Switching output	
Telegrams upon triggering	are sent
Value of the switching object	1 ... 0 (1)
Value of the value object in percent	1-100 (100)
Telegram at end of follow-up time	is sent
Value of the switching object	1 ... 0 (0)
Value of the value object in percent	1-100 (0)

No	Name	Function	C	R	W	T	U
52	A1: Output (DPT 5.001)	Value	C	-	-	T	-
53	A1: Output (DPT 1.001)	Switching	C	-	-	T	-
43	A1: Input (DPT 5.001)	Trigger value	C	-	W	-	-

### 8.4 Scene number

With the "Scene number" option, a taught-in scene (0-63) can be called up. This applies upon triggering or at the end of the follow-up time.

Switching output	
Telegram upon triggering	is sent
Scene	0 ... 63 (1)



Switching output	
Telegram at end of follow-up time	is sent
Scene	0 ... 63 (2)

No	Name	Function	C	R	W	T	U
52	A1: Output (DPT 17.001)	Scene	C	-	-	T	-

### 8.5 Cyclical sending

The status of the channel can be sent cyclically upon activation of this parameter. This enables a "heartbeat" to be realised. The "1" or "0" telegram is sent accordingly. Failure or loss of the detector can thus be monitored at all times.

Switching output	
Cyclical sending	<b>deactivated</b>
	activated

Switching output	
Cycle time in seconds <i>(visible for activation)</i>	1 ... 255 (10)

## 9. Additional functions

The "Additional functions" menu contains settings that concern manual control.

### 9.1 Manual switch-on with sufficient ambient light

Upon activation, the button can be used to switch on the lights even though the brightness threshold has been exceeded and the detector would not normally switch on the light. If this parameter is deactivated, manual switching on is only possible if the brightness level is below the threshold.

When this parameter is activated, a "Manual switch-on" menu appears to the left.

In this menu, a "switch-off time in minutes" can now be defined. After this duration, the detector switches the lights back off if the preset brightness threshold is exceeded.

Additional functions	
Forced switch-off after manual switch-on with sufficient ambient light	<b>deactivated</b>
	activated

Additional functions	
Forced switch-off after (minutes) <i>(visible for activation)</i>	1 ... 255 (15)

### 9.2 Status or function after manual switch-off or end of follow-up time

Depending on the selections for the following parameters, an additional menu appears on the left:

- inactive  
The lights are switched off and the follow-up time is stopped and reset. When the next movement is detected, the detector switches the lights on again.

- switch-off warning (manual off and end of follow-up time)

- i** The advance warnings are especially important in stairwells. The lights are briefly switched off then back on again before the follow-up time expires. This warns the person that the lights will soon be switched off if no movement is detected or no switch is pressed.

The "Switch-off warning" menu appears. Here, the user can determine in switching mode how many advance warnings there should be and at what warning point they should be triggered before the lights are finally switched off.

In regulation mode, the detector first switches the lights to 40% and then slowly down to 10%. After the configured time, the lights are turned off completely.

In switching mode, the number of advance warnings and the time of these warnings can be selected.

- Projector/Corridor (manual off)

*The functions differ from each other as follows:*

- i** In **corridor function**, the lights remain off after manual switch-off for a configurable short duration, even if movement is detected, so that the room can be vacated.

This function is primarily suitable for corridors and stairwells.

- i** In **projector function**, the lights remain off after manual switch-off for as long as motion is detected, plus the delay time that was set. This function is suitable for conference rooms and classrooms, where projectors/overhead projectors are used. The lights can also be switched back on before the delay time expires via pressing of the button.

If the parameter is selected, the "Projector/Corridor" menu appears on the left. The corresponding function can be selected here.

If "Corridor" is selected, the length of time needed to vacate the room can be set.

The activation/deactivation of the function can be overwritten via a group object and/or remote control if required. When this parameter is activated, the corridor function is active upon sending of a "1" telegram and the projector function upon sending of a "0" telegram.

Additional functions	
Status or function for manual switch-off or end of follow-up time	inactive
	Switch-off warning
	<b>Projector/Corridor</b>

Switch-off warning	
Number of advance warnings	1 ... 3 (3)

Switch-off warning	
Switch-off warning point in seconds	1 ... 255 (30)

Projector/Corridor	
Function	Projector
	<b>Corridor</b>

Projector/Corridor	
Waiting period corridor function in seconds	1 ... 255 (10)

**The ETS programming is overwritten.**

The function changed here can be overwritten via ETS download if required.

Projector/Corridor	
Function overwritable	<b>deactivated</b>
	via group object
	via remote control
	via group object and remote control

Modified function by ETS download <i>(only visible for group object or remote control)</i>	<b>overwritable</b>
	not overwritable

**The ETS programming is overwritten.**

No	Name	Function	C	R	W	T	U
46	A1: Input (DPT 1.002)	Change Corridor=1 Projector=0	C	-	W	-	-

**9.3 Orientation light (switching)**

**i** In switching mode, detectors with integrated LEDs (NOTE DEVICE VARIANT) have the option of an orientation or night light. The night light of the detector is switched on regardless of whether or not motion is detected once the brightness level has dropped below the threshold. The brightness of the night light can be varied on a percentage scale and provides basic lighting in dark areas.

If movement is then detected in such an area, the detector switches from the night light to the orientation light. This is generally set to be a little brighter so that the person present can open the door or find the light switch. In contrast to the night light, the orientation light can also be configured to come on for a limited time.

**!** The orientation and night light function are only active if "Switching depending on brightness" is activated for light output A1.

If the "Orientation light" parameter is activated, an additional menu with the same name appears on the left. The following options can be selected here:

Additional functions	
Orientation light	<b>deactivated</b>
	activated

**9.3.1 Brightness (of orientation light) LEDs in percent**

The brightness can also be selected for the orientation light. This is done in 5% increments. The follow-up time (duration in minutes) can also be selected freely.

**9.3.2 Movement analysis**

This parameter can be used to determine whether the orientation light is controlled by the master device for the entire master-slave system or whether every device in the master-slave system takes on control via the orientation light itself.

**9.3.3 Orientation light function**

The orientation light can be switched on due to the brightness level falling below the threshold or movement being detected, or it can be switched on via an object. This object can, for example, be linked to a time switch in order to enable a night mode. The function can thus be released with a "1" telegram and the orientation light switched on in the dark.

Orientation light	
Brightness LEDs in percent	1 ... 100 (100)

Orientation light	
Duration in minutes	1 ... 255 (5)

Orientation light	
Motion detection	locally in every device
	<b>globally by the entire master-slave system</b>

Orientation light	
Orientation light function	<b>released</b>
	can be activated by object

No	Name	Function	C	R	W	T	U
45	A1: Input (DPT 1.001)	Activation orientation light	C	-	W	-	-

**9.4 Night light (switching)**

If the "Night light" parameter is activated, an additional menu with the same name appears on the left. The following options can be selected here:

Additional functions	
Night light	<b>deactivated</b>
	activated

**9.4.1 Brightness (of night light) LEDs in percent**

The brightness of the LEDs can be selected for the night light. This is done in 5% increments.

**9.4.2 Night light function**

The night light can be switched on due to the brightness level falling below the threshold regardless of movement being detected, or it can be switched on via an object. This object can, for example, be linked to a time switch in order to enable a night mode. The function can thus be released with a "1" telegram and the night light switched on in the dark.

Night light	
Brightness LEDs in percent	1 ... 100 (50)

Night light	
Night light function	released
	can be activated by object

No.	Name	Function	C	R	W	T	U
44	A1: Input (DPT 1.001)	Activation night light	C	-	W	-	-

### 9.5 After bus voltage return

Here, the status of the orientation and/or night light function (released or blocked) is determined.

### 9.6 Orientation light and night light after manual switch-off

In the "Additional functions" menu, the night and/or orientation light can be activated/deactivated after manual switch-off of the main light. If this parameter is set to "activated", the light switches to the percentage set for the orientation light for the correspondingly configured follow-up time after the light is switched off manually. If motion is detected, the main light is switched back on. After the follow-up time of the orientation light has elapsed, the detector sets the light to its night light brightness. In this mode, there must be a manual intervention (button press) in order to switch the light back on.

Orientation light	
Orientation light and night light after manual switch-off	deactivated
	activated

### 9.7 Orientation light and night light global control of slave LEDs

The orientation light and night light can be controlled either locally (by every detector individually) or globally (the master device decides). In the case of local control, each device switches the orientation and night light on if it detects a movement or if the brightness drops below the preset threshold.

In the case of global control, the master device takes over control across the entire group. Movement and brightness analysis then also take place exclusively in the master device in this case.

In the case of global control, the master device communicates with the master-slave system.

- LED control -1- sends the information as to whether the LED is to be switched on at the slave device.
- LED control -2- sends the information about the detected motion.
- LED control -3- sends the status "too bright" yes or no.

**i** These objects must each be linked in separate group addresses within the master-slave system.

Orientation light	
Orientation light and night light global control of slave LEDs	deactivated
	activated

No.	Name	Function	C	R	W	T	U
57	A1: Output (DPT 1.002)	LED control -1-	C	-	-	T	-
58	A1: Output (DPT 1.002)	LED control -2-	C	-	-	T	-
59	A1: Output (DPT 1.002)	LED control -3-	C	-	-	T	-

### 9.8 Central OFF

The "Central OFF" parameter enables the lights to be switched off with an optional time delay. This can be defined in the "Central OFF" menu when the parameter is activated.

If a "0" telegram is sent to this object, the detector switches off the light if no motion is detected. Otherwise, the light remains switched on. If, after the light has been switched off by the central OFF function, movement is detected and the brightness level is below the threshold, the light is switched back on. If a movement is detected within the delay period, the light remains switched on. This ensures that lights are only switched off in unoccupied rooms.

Additional functions	
Central OFF	deactivated
	activated

Central OFF	
Delay time central OFF function in seconds (0 = directly OFF) <i>(visible for activation)</i>	0 ... 60 (0)

No.	Name	Function	C	R	W	T	U
1	General: Input (DPT 1.001)	Central OFF	C	-	W	-	-

### 9.9 Lock

If the "Lock" parameter is activated, a new "Lock" menu appears on the left. Locking can be effected with a "1" or "0" telegram.

The parameter "Behaviour upon activation of lock" has the following selection options:

- No switching back on  
The light remains switched on until no more movement is detected during a follow-up time. The lock becomes active after switching off.
- Lock only  
The current status of the light is preserved for the duration of the lock.
- Lock and send value  
A defined status (on or off) is set upon locking.

"Behaviour upon deactivation of lock" has the following options:

- Unlock  
The lock is simply removed.
- Unlock and send value  
The lock is removed in a defined manner (on or off).

#### 9.9.1 Apply time limit to lock

As a rule, the lock remains in place until it is removed by an unlocking telegram.

There is the option to enter a duration for the lock using the parameter "Apply time limit to lock", after which the lock is automatically removed. The lock can be modified without ETS. A sent "1" telegram activates the lock and a sent "0" telegram deactivates it.

#### 9.9.2 Upon bus voltage return

The user can decide whether or not the device is to be locked upon bus voltage return.

Additional functions	
Lock	<b>deactivated</b>
	activated

Lock	
Lock with	<b>1</b>
	0

Lock	
Behaviour upon activation of lock	<b>no switching back on</b>
	lock only (current status is preserved)
	lock and send value(s)

Lock	
Behaviour upon deactivation of lock	unlock
	<b>unlock and send value(s)</b>

Lock <i>(only visible for "unlock and send value(s)")</i>	
Value in %	"1"
	"0"

Lock	
Apply time limit to lock	<b>deactivated</b>
	activated

Lock time-limited	
Locking time in minutes <i>(visible for activation)</i>	0 ... 59 ( <b>0</b> )

Lock time-limited	
Locking time in hours <i>(visible for activation)</i>	0 ... 24 ( <b>12</b> )

Lock	
Upon bus voltage return	<b>not locked</b>
	locked

No.	Name	Function	C	R	W	T	U
29	A1: Input (DPT 1.001)	Lock	C	-	W	-	-

The ETS programming is overwritten by the remote control when the lock is configured.

### 9.10 Behaviour upon bus voltage return

**⚠ ATTENTION:** During connection with the bus, the detector is in its basic settings. The light remains switched off until the detector has called up the parameters.

With this parameter, the behaviour of the detector upon bus voltage return is defined:

- Same as for channel deactivation  
The detector behaves as though the channel had been switched off.  
The light is switched off.
- Same as for channel activation  
The detector behaves as though the channel had been switched on.  
The light is switched on.
- Same behaviour as before bus voltage loss  
The detector behaves in the same way as it did before the bus voltage loss.

Additional functions	
Behaviour upon bus voltage return	<b>Same as for channel deactivation</b>
	Same as for channel activation
	Same behaviour as before bus voltage loss

### 9.11 Additional settings for motion sensor(s) (NOTE DEVICE VARIANT)

Upon activation of this parameter, a "Motion sensor(s)" menu appears on the left.

#### 9.11.1 Safety delay

The safety delay ensures that the detector does not immediately switch back on again after being switched off if it detects movement. This is based on the fact that certain lights build up heat radiation that can lead to incorrect switching.

This delay can be set between 0 and 255 seconds depending on the heat build-up of the light.

#### 9.11.2 Same settings for all sensors (NOTE DEVICE VARIANT)

When this parameter is activated, all sensors are operated with the same sensitivity. Upon deactivation, the settings can be configured for up to 4 sensors depending on the device variant.

**i** This function can be used to hide the sensors or make them less sensitive. This can therefore eliminate the need for blinds. Furthermore, the deactivation of the sensors can also be used across all of channels A1 to A4 to assign each motion sensor its own channel.

The motion sensors are marked with the numbers 1 to 4 (see figure with example PD4).

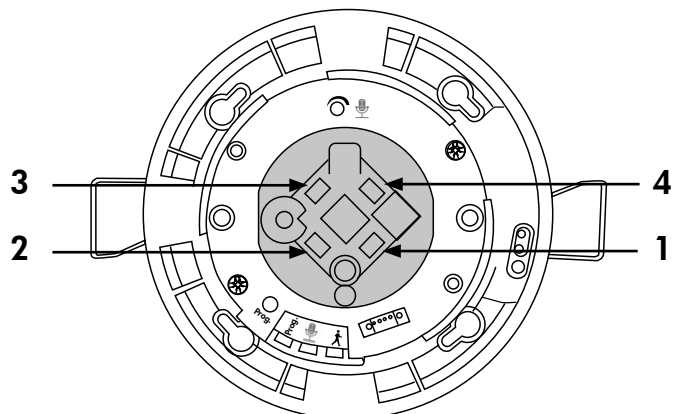

For example, in a T-shaped corridor the motion sensors S1 to S4 can be configured as shown in the image and the outputs A1 to A3 arranged so as to control the lights in the individual parts of the corridor.

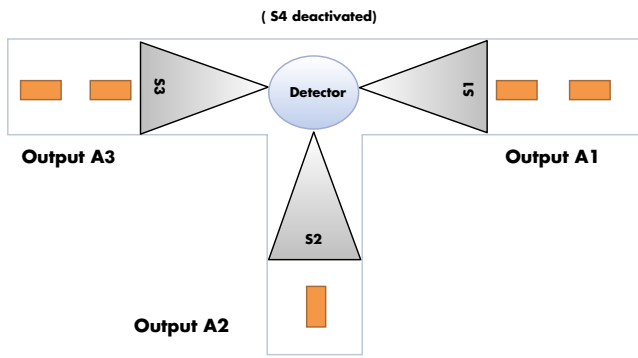

### 9.11.3 Sensitivity sensor

The sensitivity of the sensors can be set to a value between "1" (insensitive) and "10" (sensitive). If the setting "0" is selected, the corresponding sensor is deactivated.

### 9.11.4 Sensitivity configurable

The sensitivity of the sensors can be configured without ETS if required by way of a group object and/or remote control.

Additional settings for motion sensors	
Safety delay in seconds	0 ... 255 (3)

Additional settings for motion sensors	
Same settings for all sensors	activated
	deactivated

Additional settings for motion sensors	
Sensitivity can be modified	deactivated
	via group object
	via remote control
	via group object and remote control

Modified sensitivity by ETS download	overwritable
<small>(only visible for group object or remote control)</small>	not overwritable

### The ETS programming is overwritten.

The function changed here can be overwritten via ETS download if required.

No.	Name	Function	C	R	W	T	U
47	A1: Input (DPT 5.001)	Sensitivity sensors	C	-	W	-	-

Upon deactivation of the parameter "Same settings for all sensors", further parameters are displayed.

No.	Name	Function	C	R	W	T	U
47	A1: Input (DPT 5.001)	Sensitivity of sensor 1	C	-	W	-	-
48	A1: Input (DPT 5.001)	Sensitivity of sensor 2	C	-	W	-	-
49	A1: Input (DPT 5.001)	Sensitivity of sensor 3	C	-	W	-	-
50	A1: Input (DPT 5.001)	Sensitivity of sensor 4	C	-	W	-	-

### 9.12 Sound sensor

See section 3.4

## 10. Occupancy detector (operation mode offset switching)

**i** This operating mode makes it possible to operate up to three lighting runs with an offset.

This function can be used in classrooms, such as in the manner shown in the figure. The light value for the class is preset at the wall side. As the intensity of the artificial light decreases due to the daylight, there is the most daylight at the window side and lighting run 3 is switched off first. Depending on how much daylight enters the room, lighting run 2 is switched off. If the brightness threshold is exceeded throughout the room, all the lights are switched off.

In the reverse order, lighting run 1 is switched back on first at dusk. Lighting runs 2 and 3 are then gradually switched on as well. The detector must be placed as shown in the figure and the light sensor must be pointing towards the wall side.

The calibration process begins when the brightness drops below the threshold. First of all, the lighting run on the wall side is switched on and the increase in light is measured after the calibration period (determination of the switch-off threshold). The second lighting run is now switched on and the increase in light is measured once again. After the third lighting run has been switched on, the measurement is complete for the lighting run on the window side once the calibration period has elapsed.

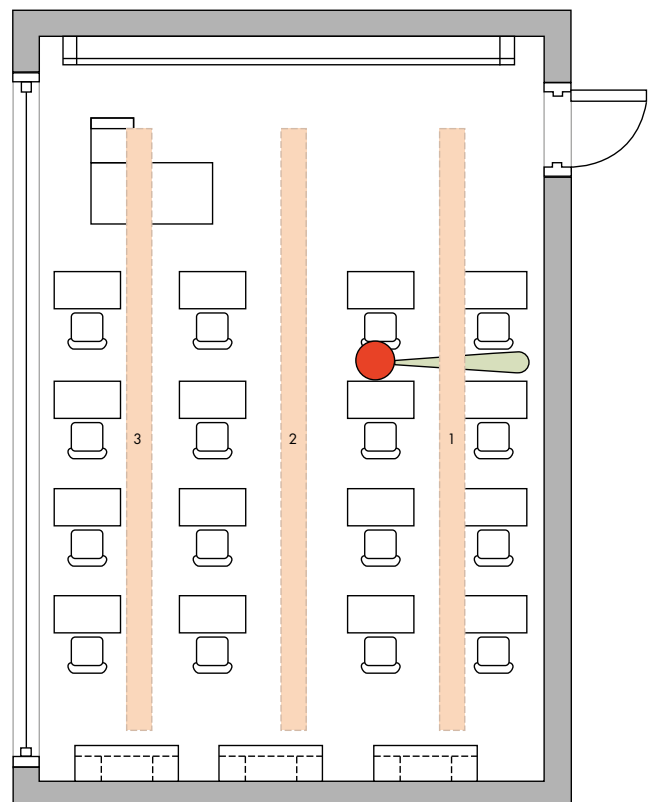

Picture 1

### 10.1 Switch-on threshold for switching channel 1 in lux

Here, the switch-on threshold for the room is determined. If the value drops below this threshold, the light switches on if movement is detected. The following parameters are used to define the offset of lighting runs 2 and 3.

### 10.2 Brightness level measured at the window side while group 2 is switched on (in percent)

The light value at the window side must be measured if lighting runs 1 and 2 are switched on. The percentage of the configured switch-on threshold is then entered in order to determine the threshold for lighting run 3.

**i** To manually control the lighting runs separately, please proceed as instructed in section 13.

A1: Occupancy detector (offset)	
Switch-on threshold for switching channel 1 in lux	5 ... 2000 (500)

A1: Occupancy detector (offset)	
Brightness value measured at the window side while group 2 is switched on	0 ... 100 (50)

No.	Name	Function	C	R	W	T	U
52	A1: Output (DPT 1.001)	Lighting group 1 (wall side)	C	-	-	T	-
53	A1: Output (DPT 1.001)	Lighting group 2 (centre)	C	-	-	T	-
54	A1: Output (DPT 1.001)	Lighting group 3 (window side)	C	-	-	T	-

### 11. Occupancy detector (operation mode regulation)

When using the detector in regulation mode, the detector sends a telegram to the actuator via a value object (DIM, DALI) for daylight-dependent regulation. The detector therefore regulates the connected lighting to the configured set value brightness, depending on motion and the influence of daylight.

**⚠ ATTENTION:** daylight-dependent regulation can only be implemented up to an installation height of max. 5 m. If the detector is mounted any higher, only the orientation light function can be used to provide basic lighting if there is no movement.

#### 11.1 Set value brightness

When the configured value is exceeded, the detector dims the lighting and switches it off in accordance with the settings if sufficient daylight is present.

Please see section 13 for manual regulation.

#### 11.2 Set value brightness overwritable

The set value brightness can be overwritten by way of a group object and/or remote control if required. If the "Set value brightness overwritable" parameter is activated, group object 36: "A1: Input - Set Value 1" appears (DPT 9.004).

### 11.3 Additional set value/fixed value

**i** An additional set value can be defined here. It is possible to switch between set value 1 and set value 2 via an object. Usage example: In sports halls, two different light values are required for training and competitions, which can be switched accordingly by the staff. Set value 1 is active when a "0" telegram is sent to the corresponding object and set value 2 when a "1" telegram is sent.

#### 11.3.1 Fixed value in percent

As a further option, an additional fixed value can be defined in percent, for example in order to provide full brightness for cleaning operations. The last used set value is active when a "0" telegram is sent to this object and the fixed value is active when a "1" telegram is sent.

Set value brightness	
Set value brightness in lux	5 ... 2000 (500)

Set value brightness	
Set value brightness overwritable	<b>deactivated</b>
	via group object
	via remote control
	via group object and remote control

Modified set value brightness by ETS download	<b>overwritable</b>
<i>(only visible for group object or remote control)</i>	not overwritable

The ETS programming is overwritten.

Set value brightness	
Additional set value/fixed value	<b>deactivated</b>
	activated

Set value brightness	
Set brightness value 2 in lux	5 ... 2000 (1200)
<i>(visible for activation)</i>	

Set value brightness	
Fixed value in percent	0 ... 100 (100)
<i>(visible for activation)</i>	

No.	Name	Function	C	R	W	T	U
52	A1: Output (DPT 5.001)	Dimm value (group near detector)	C	-	W	T	U
36	A1: Input (DPT 9.004)	Set value 1	C	-	W	-	-
37	A1: Input (DPT 1.002)	Change set value	C	-	W	-	-
38	A1: Input (DPT 1.002)	Change set value/fixed value	C	-	W	-	-

### 12. Regulating outputs

In this parameter menu, all the settings that affect the regulation behaviour of the detector can be configured.

## 12.1 Startup behaviour

Here, the behaviour during switch-on is defined. The light can either be increased from low intensity until it reaches the set value brightness, jump to a preset percentage, or switch on at a calculated value near the set value brightness.

Regulation output	
Startup behaviour	Soft start
	Jump to a fixed value
	<b>Jump to a calculated value</b>

### 12.1.1 Soft start

With this setting, the lighting is controlled upwards from low intensity until it reaches the configured set value. This avoids dazzling anyone who is leaving the room and allows the eyes to get used to the lighting conditions.

The step size of the dimming process can be set as a percentage. The speed of the soft start can be determined by the delay in milliseconds.

#### Relative dimming

When this parameter is activated, the soft start is implemented via the 4-bit object "relative dimming" (see figure below). This object must therefore be connected to the 4-bit object of the actuator. This decreases the bus load, as the detector automatically works with start/stop telegrams. The status (8-bit object) of the dimming actuator must be read out here in order to obtain the current status. The same group address can be used as for the control value (object 52, 8 bit). The subsequent regulation is then controlled with the 8-bit control object.

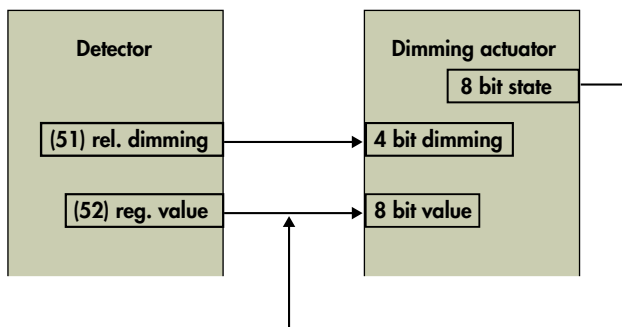

For manual regulation via external command, a separate group address must be used for the 4-bit soft start and the external command 4-bit regulation (see section 13).

Regulation output	
<b>- Soft start</b>	
Step size in percent	1 ... 10 (4)

Regulation output	
<b>- Soft start</b>	
Delay time in milliseconds	100 ... 2000 (500)

No.	Name	Function	C	R	W	T	U
51	A1: Output (DPT 3.007)	Relative dimming	C	-	-	T	-

### 12.1.2 Jump to a fixed value

The start value can be defined in 5% steps. The lighting starts with the preset value and then goes into regulation.

The start value can be modified without ETS if required by way of a group object and/or remote control.

Regulation output	
<b>- Jump to a fixed value</b>	
Start value in percent	0 ... 100 (50)

Jump to a fixed value	
Start value modifiable via group object	<b>deactivated</b>
	activated

No.	Name	Function	C	R	W	T	U
43	A1: Input (DPT 5.001)	Start up value	C	-	W	-	-

### 12.1.3 Jump to a calculated value

With this setting, the lighting starts up with a calculated value. After the learning time has been completed correctly (see section 12.2), this is near the configured set value brightness. After download, or if the learning time has not been completed correctly, the lighting starts up at 50%.

## 12.2 Learning time after start

The learning time specifies the amount of time that the detector needs in order to detect the lighting conditions in the room, as well as the amount of time that the light needs in order to reach its full brightness. The learning time must be completed once after download in order to fully complete the learning process. If the configured follow-up time is shorter than the learning time, the follow-up time must be restarted by a movement so that the learning time can end as planned. If the learning process is not fully completed, an approximate value will be used in the "soft start" setting. In the setting "Jump to a calculated value", the light jumps to 50%.

Regulation output	
Learning time after start in minutes	1 ... 255 (2)

## 12.3 Hysteresis

This is the percentage that is added to the set value brightness to obtain a tolerance between the switch-on and switch-off value. This prevents the light switching back on due to the value falling below the set value brightness immediately after it has been switched off due to the set value being exceeded.

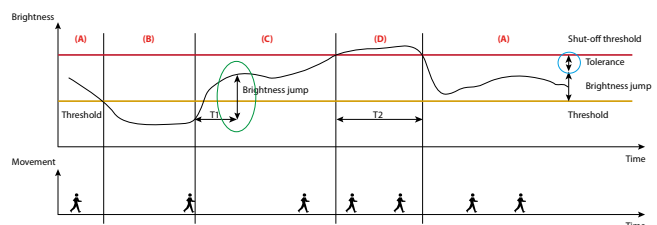

- (+) Light value
- (+) Daylight influence
- (+) Tolerance
- (=) Switch-off value

Regulation output	
Hysteresis in percent	5 ... 20 (10)

## 12.4 Minimum regulation time/maximum regulation step

The parameters "Minimum regulation time" and "Maximum regulation step" together influence the regulation speed of the detector.

The parameter "Minimum regulation time" serves to prevent excessively fast regulation due to short-term changes in the lighting conditions. If very significant changes to the lighting occur in the room, the detector can react by taking large jumps in its regulation in some cases. The parameter "Maximum regulation step" can therefore be used to define the maximum size of a regulation step (in percent).

Regulation output	
Minimum regulation time in seconds	1 ... 10 (1)
Maximum regulation step in percent	1 ... 10 (10)

## 12.5 Regulation minimum

This parameter defines the smallest value to which the light should be regulated, either manually or automatically, due to the presence of sufficient daylight. If this value is set at  $\leq 10\%$ , the "Switch-off delay at regulation minimum" begins (see section 12.6). During this time, the detector monitors the brightness in the room. If this is consistently above the set value brightness, the detector turns the light off once the time has elapsed.

If the configured value is above 10%, the light is dimmed to this value if sufficient daylight is present, but is not switched off. The light is only switched off in this case if no further movement is detected during a follow-up time.

If the set value brightness is below the current brightness value, the light is not automatically switched on when the room is entered. However, it can be switched on manually via a button. In the status "too bright", the light is switched to a value of 10% for a configuration of  $\leq 10\%$  and is switched off again after a defined period of 15 minutes if the set value brightness is consistently exceeded. For a configuration above 10%, the light is switched on with the selected value in the status "too bright" by pressing a button, and daylight-dependent switch-off is deactivated.

Regulation output	
Regulation minimum value in percent	5 ... 20 (10)

## 12.6 Switch-off delay for regulation minimum $\leq 10\%$

If the set value brightness configured on the detector is exceeded, the detector first dims the light to the regulation minimum. A configurable time period now begins, during which the level is monitored to see if the set value is exceeded. If the level remains above the set value for the configured time period, the detector switches the light off once the time has elapsed.

Regulation output	
Switch-off delay for regulation minimum $\leq 10\%$ in minutes	1 ... 255 (10)

## 12.7 Waiting period after switch-off at regulation minimum in semi-automatic mode

This parameter only relates to semi-automatic mode and has the effect that the detector turns the light back on automatically after it has been switched off due to the increasing daylight if movement is detected and

the brightness level drops back below the threshold. The configured follow-up time is used as the basis for this.

Control outputs	
Waiting period after switch-off at regulation minimum in semi-automatic mode	deactivated
	<b>activated</b>

## 12.8 Light groups 2 and 3

**i** In a similar manner to offset switching mode, when this parameter is activated it can be used to operate up to three lighting runs with an offset and to regulate them based on the daylight in order to ensure that the room is lit evenly.

This function is used in classrooms, for example (see figure 1 in section 10). In contrast to offset switching mode, the control value is measured in the middle of the room here.

Accordingly, the control value (object 52, Output – Regulation value (group near detector)) is the lighting run in the middle of the room (light group 1).

As the intensity of the artificial light decreases because of the daylight, light group 3 on the window side is the first to dim its lights. A negative offset is therefore specified here. The least daylight reaches the room at the depth of light group 2, which is on the wall side. The amount of artificial light added for lighting group 2 is therefore higher than that for light group 1 in the middle of the room, and a positive offset is defined. The artificial light proportion and thus also the offset value decrease from the wall to the window side. If the regulation rate is below 30% or above 70%, the offset is deactivated and the lights are dimmed uniformly.

Regulation output	
Light groups 2 and 3	deactivated
	activated

Regulation output	
Offset between regulation value and group 2 in percent <i>(visible for activation)</i>	-99 ... +99 (20)
Offset between regulation value and group 3 in percent <i>(visible for activation)</i>	-99 ... +99 (-20)

No.	Name	Function	C	R	W	T	U
53	A1: Output (DPT 5.001)	Light group 2	C	-	-	T	-
54	A1: Output (DPT 5.001)	Light group 3	C	-	-	T	-

## 12.9 Cyclical sending

The start value in percent can be sent cyclically once this parameter is activated. This makes it possible to realise a "heartbeat", where a "1" or "0" telegram is sent accordingly. Failure or loss of the detector can thus be monitored at all times.

Regulation output	
Cyclical sending	deactivated
	activated



Regulation output	
Cycle time in seconds	1 ... 255 (10)

### 13. External commands

Using the objects 32 "Input – External switching", 33 "Input – External regulation" and 34 "Input – External value" listed in this menu, an actuator can be influenced directly by bypassing the detector, where the detector is informed of the direct control of the actuator. The detector gives up regulation here, but continues to monitor and take into consideration the motion detection and follow-up time. The status brought about via the objects 32, 33 and 34 is thus preserved for as long as the detector detects movement plus the configured follow-up time.

If the automatic mode is reactivated before the follow-up time ends, group object 31 "Input – Manual control" can be used to send a "0" and "1" telegram by briefly pressing a button to reactivate regulation via the detector.

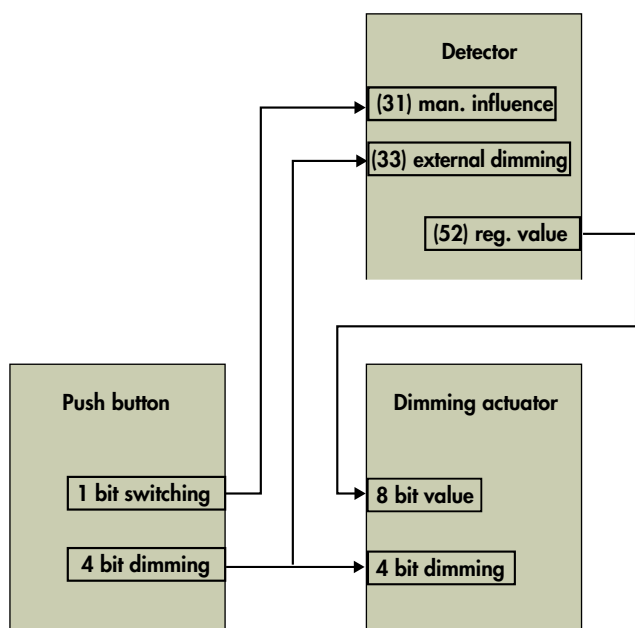

Picture 1  
This applies to both switching and regulation mode.

In the "soft start" setting, the 4-bit object of the button must be linked with the input object of the detector using a separate group address for manual regulation (without the 4-bit object of the detector, see figure 2).

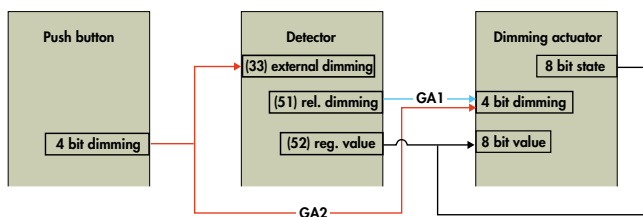

Picture 2

A1 Occupancy detector	
External commands	deactivated
	activated

No.	Name	Function	C	R	W	T	U
32	A1: Input (DPT 1.001)	External switching	C	-	W	-	-

No.	Name	Function	C	R	W	T	U
33	A1: Input (DPT 3.007)	External regulation	C	-	W	-	-
34	A1: Input (DPT 5.001)	External value	C	-	W	-	-

### 14. Additional functions in regulation mode

#### 14.1 Orientation and night light (regulation)

In regulation mode, it is possible to use both the internal LEDs and external lights for the orientation or night light. In the menus "Orientation light" and "Night light", it is possible to choose whether to activate the internal LEDs and/or the external lights. If the external lights are activated, the brightness can be defined in 5% steps.

Orientation light	
internal LEDs	deactivated
	activated

Orientation light	
external lights	deactivated
	activated

Orientation light	
Brightness of the external lights in percent	0 ... 100 % (20)

Night light	
internal LEDs	deactivated
	activated

Night light	
external lights	deactivated
	activated

Night light	
Brightness of the external lights in percent	0 ... 100 % (10)

#### 14.2 Burn-in function (lamp)

**i** Before they are dimmed, new fluorescent lamps should be burned in for a certain period, to ensure a long life and flicker-free operation. The application provides a parameter for this, "Burn-in function", which can be activated or deactivated. This can be done via a group object or remote control. When the function is activated, the detector runs the burn-in function for the configured time period in the same manner as in switching operation. The light is switched on and off only but is not regulated and cannot be manually dimmed via the detector either. After the configured time period has elapsed, the detector automatically switches to regulation mode and manual regulation is now also possible via a long button press.

If necessary, the burn-in function can be cancelled early or paused so that it can be completed at a later time. The group object 39 "A1: Input – Burn-in start/stop" can be used for this. The function is switched on/started with a "1" telegram and can be interrupted/cancelled with a "0" telegram.

The remaining duration of the burn-in time can be called up via a group object. It is therefore possible to display the remaining time in minutes. The user can also decide whether the burn-in time should be restarted after bus voltage return or whether the behaviour before the bus voltage loss should be preserved.

Burn-in function	
Start burn-in function	via group object
	via remote control
	via group object and remote control

Burn-in function	
Burn-in time in hours	1 ... 100 (100)

Burn-in function	
Burn-in function	cannot be interrupted/ cancelled
	can be cancelled
	can be interrupted

Burn-in function	
Behaviour upon bus voltage return	Same behaviour as before bus voltage loss
	Restart

Burn-in function	
Remaining burn-in time can be called up	deactivated
	activated

No.	Name	Function	C	R	W	T	U
39	A1: Input (DPT 1.010)	Burn-in start/stop	C	-	W	-	-
40	A1: Input (DPT 1.010)	Call up remaining burn-in time	C	-	W	-	-
56	A1: Input (DPT 7.006)	Remaining burn-in time	C	-	-	T	-

### 14.3 Adjustment of the dimming curve

The DALI dimming behaviour is adapted to the human eye. This serves to improve wellbeing. Dazzling of the eyes is avoided. If a DALI curve is stored, for example in the case of a dimming actuator for 1-10V, this parameter can be used to define the dimming curve of the actuator using five points so that a linearity is generated here too and the comfort of the DALI dimming behaviour can be felt.

DALI electronic ballasts behave exponentially in relation to the light curve. The changes at the output are rather low at first and become larger towards the end.

When a DALI/KNX gateway is used the system becomes linearised; the inverse function is formed. Here, it is not necessary to adjust the curve in the detector.

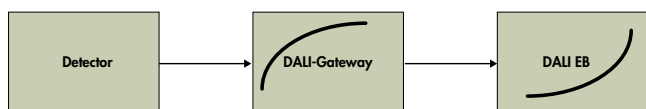

If a dimming actuator with a different curve profile is used, the detector requires the corresponding adjustment values of the curve profile.

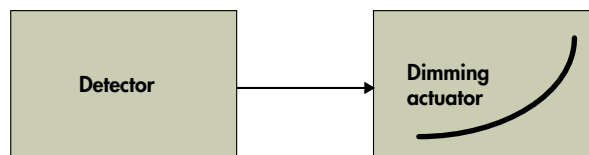

An "Adjustment of the dimming curve" menu appears on the left. For point 1, the values for dimming input and dimming output are each defined as 0%. Points 2 to 4 can be freely configured in 5% increments. Point 5 is set at 100%.

Additional functions	
Adjustment of the dimming curve	deactivated
	activated

Adjustment of the dimming curve (point 1)	
Dimming input in percent	0 %
Dimming output in percent	0 %
Adjustment of the dimming curve (point 2)	
Dimming input in percent	0 ... 100 % (25)
Dimming output in percent	0 ... 100 % (25)
Adjustment of the dimming curve (point 3)	
Dimming input in percent	0 ... 100 % (50)
Dimming output in percent	0 ... 100 % (50)
Adjustment of the dimming curve (point 4)	
Dimming input in percent	0 ... 100 % (75)
Dimming output in percent	0 ... 100 % (75)
Adjustment of the dimming curve (point 5)	
Dimming input in percent	100 %
Dimming output in percent	100 %

## 15. Slave (SL)

Slave devices are used to increase the detection area and send information to the master device when they detect movement. The benefit of the Gen6 detectors is that the master functions are preserved when the device is configured as a slave. This means that a master device can also function as a slave for another master device.

The "Slave" parameter can be activated in the "Detector outputs" menu. The group object 25 (SL: Output - Slave (SL)) can now be linked with the group object 30 (A1: Input - Slave (SL)) of the master device.

In simple systems, it is enough to connect all slave outputs to the master device's slave input. If a slave device detects a movement, it sends this information to the master device. The master device takes over all logical evaluation, such as brightness detection and specification of follow-up time, and switches on as required.

### 15.1 Locking time

In order to minimise the load on the KNX bus from telegrams, telegrams from slave devices are sent at a particular interval. The duration between telegrams can be set via this parameter in seconds and minutes. If the master device switches off at the end of the follow-up time, the block time of the slave device must also be reset so that the information can again be immediately sent to the master device the next time.

movement is detected. To this end, group object 13 (SL: Input – Reset) of the slave device is connected to group object 61 (A1: Output – Reset) of the master device.

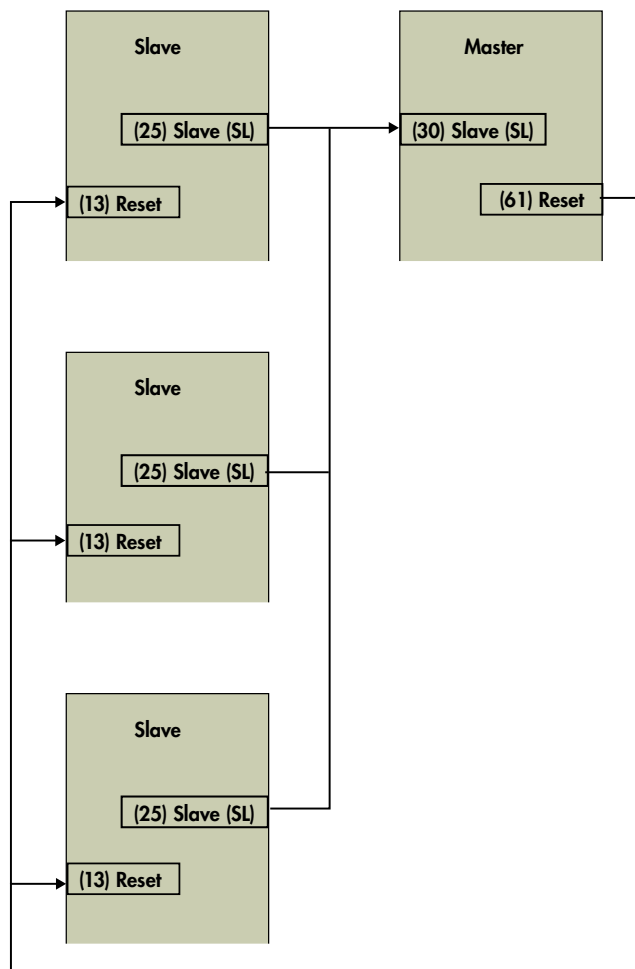

## 15.2 Additional functions

The orientation and night light can be configured in this menu (see sections 9.3 and 9.4). If localised brightness analysis is activated for the night and orientation light, a switch-on threshold can be defined. In this case, the detector switches the orientation light on when the level falls below the threshold and movement is detected, and switches the night light on if the level falls below the threshold but no movement is detected. For global control of the LEDs, the group objects 57-59 must be connected as described in section 9.7.

Slave function (SL)	
Locking time	
Locking time in seconds	0 ... 59 (0)
Locking time in minutes	0 ... 59 (4)

No.	Name	Function	C	R	W	T	U
13	SL: Input (DPT 1.002)	Reset	C	-	W	-	-
25	SL: Output (DPT 1.002)	Slave (SL)	C	-	-	T	-

## 16. HVAC channels (A2-A4)

The detector has three HVAC channels (A2-A4). The channels are switching outputs and can be activated due to movement independently of the ambient light, but also switch depending on the ambient light, in other words in the same manner as light output A1 in switching mode.

Each of the three channels is independent and can be used individually. The functions are identical for all three channels.

Each channel has a separate push button input (manual control) and a separate slave input. The sound sensor can be used separately for each channel.

### 16.1 Follow-up time

See section 6 for a description of the "Follow-up time" menu

### 16.2 Switch-on threshold

See section 7 for a description of the "Switch-on threshold" menu (excluding the second brightness threshold and daylight-dependent switch-off).

### 16.3 Switching output

See section 8 for a description of the "Switching outputs" menu; however, the telegram can optionally be suppressed at the start or end of the follow-up time.

Switching output	
Telegram upon triggering	is not sent
	is sent

Switching output	
Telegram at end of follow-up time	is not sent
	is sent

It is also possible to operate the device in HVAC mode.

### 16.4 HVAC mode

Here, various operating modes can be selected for heating control. The heating system can operate in various modes:

Automatic – The automatic program of the heating device is active.

Comfort – The comfort temperature is activated when persons are present.

Standby – The temperature is activated when no persons are present.

Economy – The temperature is activated after night-time lowering.

Frost/heat protection – The minimum temperature is activated to prevent the lines from freezing.

The telegrams can be sent either upon triggering or after the end of the follow-up time. The 1-byte object can be freely used in a selection between 5 and 255.

Switching output	
Detector sends	Switching object
	Value object
	HVAC mode

HVAC mode	
Telegram upon triggering	is sent
	is not sent

HVAC mode	
Mode	automatic (0)
	<b>comfort (1)</b>
	standby (2)
	economy (3)
	frost/heat protection (4)

HVAC mode	
Telegram at end of follow-up time	<b>is sent</b>
	is not sent
Mode	automatic (0)
	comfort (1)
	<b>standby (2)</b>
	economy (3)
	frost/heat protection (4)

### 16.5 Additional functions

See section 9 for a description of the "Additional functions" menu (excluding the forced switch-off after manual switch-on with sufficient ambient light and excluding options for the orientation and night light).

### 16.6 Projector/corridor

See section 9.2 for a description of the "Projector/corridor" menu; however, the function cannot be switched via group object and/or remote control.

### 16.7 Central OFF

See section 9.8 for a description of the "Central OFF" menu.

### 16.8 Lock

See section 9.9 for a description of the "Lock" menu.

### 16.9 Motion sensors

See section 9.11 for a description of the "Motion sensors" menu.

### 16.10 Sound sensor

See section 9.12 for a description of the "Sound sensor" menu.

### HVAC output A2

No.	Name	Function	C	R	W	T	U
62	A2: Input (DPT 1.001)	Lock	C	-	W	-	-
63	A2: Input (DPT 1.002)	Slave (SL)	C	-	-	T	-
64	A2: Input (DPT 1.001)	Manual influence	C	-	W	-	-
65	A2: Input (DPT 7.006)	Follow-up time	C	-	W	-	-
66	A2: Input (DPT 9.004)	Threshold	C	-	W	-	-
67	A2: Input (DPT 1.002)	Change operat. Mode VA=1, HA=0	C	-	W	-	-
68	A2: Input (DPT 1.001)	Activation sound sensor	C	-	W	-	-
69	A2: Input (DPT 5.001)	Sensitivity sensors	C	-	W	-	-
69	A2: Input (DPT 5.001)	Sensitivity of sensor 1	C	-	W	-	-
70	A2: Input (DPT 5.001)	Sensitivity of sensor 2	C	-	W	-	-
71	A2: Input (DPT 5.001)	Sensitivity of sensor 3	C	-	W	-	-

No.	Name	Function	C	R	W	T	U
72	A2: Input (DPT 5.001)	Sensitivity of sensor 4	C	-	W	-	-
73	A2: Output (DPT 1.001)	Switching	C	-	-	T	-
73	A2: Output (DPT 5.001)	Value	C	-	-	T	-
74	A2: Output (DPT 1.002)	Reset	C	-	-	T	-

### HVAC output A3

No.	Name	Function	C	R	W	T	U
77	A3: Input (DPT 1.001)	Lock	C	-	W	-	-
78	A3: Input (DPT 1.002)	Slave (SL)	C	-	-	T	-
79	A3: Input (DPT 1.001)	Manual influence	C	-	W	-	-
80	A3: Input (DPT 7.006)	Follow-up time	C	-	W	-	-
81	A3: Input (DPT 9.004)	Threshold	C	-	W	-	-
82	A3: Input (DPT 1.002)	Change operat. mode VA=1, HA=0	C	-	W	-	-
83	A3: Input (DPT 1.001)	Activation sound sensor	C	-	W	-	-
84	A3: Input (DPT 5.001)	Sensitivity sensors					
84	A3: Input (DPT 5.001)	Sensitivity of sensor 1	C	-	W	-	-
85	A3: Input (DPT 5.001)	Sensitivity of sensor 2	C	-	W	-	-
86	A3: Input (DPT 5.001)	Sensitivity of sensor 3	C	-	W	-	-
87	A3: Input (DPT 5.001)	Sensitivity of sensor 4	C	-	W	-	-
88	A3: Output (DPT 1.001))	Switching	C	-	-	T	-
88	A3: Output (DPT 5.001)	Value	C	-	-	T	-
89	A3: Output (DPT 1.002)	Reset	C	-	-	T	-

### HVAC output A4

No.	Name	Function	C	R	W	T	U
92	A4: Input (DPT 1.001)	Lock	C	-	W	-	-
93	SL: Input (DPT 1.002)	Slave (SL)	C	-	-	T	-
94	A4: Input (DPT 1.001)	Manual influence	C	-	W	-	-
95	A4: Input (DPT 7.006)	Follow-up time	C	-	W	-	-
96	A4: Input (DPT 9.004)	Threshold	C	-	W	-	-
97	A4: Input (DPT 1.002)	Change operat. Mode VA=1, HA=0	C	-	W	-	-
98	A4: Input (DPT 1.001)	Activation sound sensor	C	-	W	-	-
99	A4: Input (DPT 5.001)	Sensitivity sensors					
99	A4: Input (DPT 5.001)	Sensitivity of sensor 1	C	-	W	-	-
100	A4: Input (DPT 5.001)	Sensitivity of sensor 2	C	-	W	-	-
101	A4: Input (DPT 5.001)	Sensitivity of sensor 3	C	-	W	-	-
102	A4: Input (DPT 5.001)	Sensitivity of sensor 4	C	-	W	-	-
103	A4: Output (DPT 1.001)	Switching	C	-	-	T	-
103	A4: Output (DPT 5.001)	Value	C	-	-	T	-
104	A4: Output (DPT 1.002)	Reset	C	-	-	T	-

## 17. Remote control/smartphone app

Optional remote controls are available. These are the B.E.G. Standard KNX remote control for configuration of the detectors and the bidirectional smartphone app. In addition, a 5-button remote control for end customers is available for the DX variant.

### 17.1 Remote control (27 buttons) for configuration (item no. 92123)

To this end, the IR configuration must be activated via 27-button remote control in the basic settings.

The following settings can be configured:

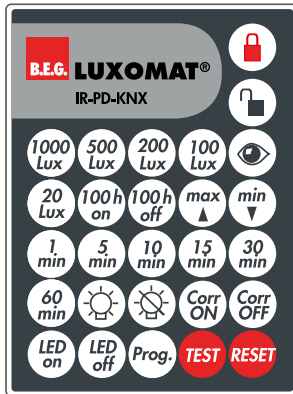

In each mode (except for when the detector is locked), the detector can be locked or unlocked with the remote control. In the locked state, only TEST and RESET are available.

**All settings configured with the remote control are not visible in ETS!**

### 17.1.1 Special functions



The "Reset" button resets the detector. Here, the detector behaves as upon bus voltage return. The parameter settings configured there are used.

**Prog.**

The "Prog." button puts the detector in programming mode in the open state, in order to program a physical KNX address.

*(This function is also available if the 5-button remote control was selected in ETS.)*

### 17.1.2 Overview of remote control functions

		Not programmed		Normal mode		Slave mode		Test mode		Locked	
		lock	unlock	lock	unlock	lock	unlock	lock	unlock	lock	unlock
											
Set value/threshold 1.000 Lux					✓				✓		
Set value/threshold 500 Lux					✓				✓		
Set value/threshold 200 Lux					✓				✓		
Set value/threshold 100 Lux					✓				✓		
Read current light value					✓						
Set value/threshold 20 Lux					✓				✓		
Switch on burn-in function					✓				✓		
Switch off burn-in function					✓				✓		
Dim up					✓						
Dim down					✓						
Follow-up time 1 min					✓				✓		
Follow-up time 5 min					✓				✓		
Follow-up time 10 min					✓				✓		
Follow-up time 15 min					✓				✓		
Follow-up time 30 min					✓				✓		
Follow-up time 60 min					✓				✓		
Light on					✓				✓		
Light off					✓				✓		
Switch on corridor function					✓				✓		
Switch off corridor function					✓				✓		
Switch on LED					✓		✓		✓		
Switch off LED					✓		✓		✓		
KNX programming button			✓		✓		✓		✓		
Test mode on/off					✓				✓		
Reset			✓		✓		✓		✓		

## 17.2 Remote control (5 buttons) for end-customers (item no. 93398)

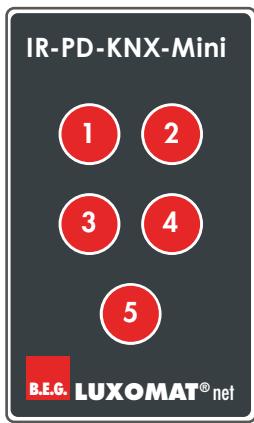

In the DX variant, a mini remote control is available for end customers that can be programmed according to their wishes and can also be used for remote control of other actuators present in the system. As the information is stored in the detector and the remote control only sends one infrared command per button, the remote control can be programmed differently in each detector.

If the freely programmable 5-button remote control is selected in the parameters, the individual buttons can be activated/deactivated in the "Button functions" menu. When a button is activated, a new menu appears on the left with the corresponding IR channel (IR1 to IR5). The numbers of the group objects depend on the IR channel. Each button can be assigned an operating mode: switching, regulation, shutters/blinds, scene.

A DX variant detector can be operated either with a 27-button remote control for configuration or with a 5-button remote control (end customer).

**Note:** The 27-button and 5-button remote control can only be used as alternatives to one another.

Basic settings	
Type of remote control	<b>5 buttons (freely programmable)</b> 27 buttons (for configuration)

The IR channels and the buttons of the 5-button remote control must be released and appear in the "Button functions" menu.

Note: The parameters for release of the IR channels for the 5-button remote control also appear when the 27-button remote control is selected. In this case, the parameters have no function and should all be set to "deactivated".

Button functions	
IR button	
IR1	<b>deactivated</b>
	activated
IR2	<b>deactivated</b>
	activated
IR3	<b>deactivated</b>
	activated
IR4	<b>deactivated</b>
	activated
IR5	<b>deactivated</b>
	activated

### 17.2.1 Operating mode: "Switching"

The selected and correspondingly configured button can be used in this operating mode for example to switch lighting, where an action can be performed through pressing and/or releasing the button.

First of all, various object types are available to choose in the parameters. With the object type "Switching", 1-bit telegrams are sent to switch on, off or toggle. In the case of priority control, a 2-bit telegram is used to switch with higher priority in order to e.g. override an automatic process. A lighting level can be specified via the percentage value (8 bit).

**Note:** In toggle mode, it is necessary for the detector to receive a reaction if the load is toggled from an external source. Either the external toggling is performed via the object/group address "Switching", which the detector also uses, or the actuator sends a reaction that must then be placed on the object/group address "Feedback toggle mode". Both options are equivalent.

IRx: IR channel	
Mode	<b>Switching</b>
	Regulation
	Blinds/roller shutter
	Scene
Object type	<b>Switching</b>
	Forced operation
	Value in %
Reaction when pressing the button <i>(Only visible for object type "Switching")</i>	No reaction
	<b>switch on</b>
	switch off
	toggle
Reaction when releasing the button <i>(Only visible for object type "Switching")</i>	<b>no reaction</b>
	switch on
	switch off
	toggle
Reaction when pressing the button <i>(Only visible for object type "Forced operation")</i>	no reaction
	<b>forced switch-on</b>
	forced switch-off
	forced operation inactive
Reaction when releasing the button <i>(Only visible for object type "Forced operation")</i>	<b>no reaction</b>
	forced switch-on
	forced switch-off
	forced operation inactive
Reaction when pressing the button <i>(Only visible for object type "Percent")</i>	no reaction
	<b>Value 0% - 100%</b>
Value in percent <i>(Only visible for value 0%-100%)</i>	0 - 100 [0]
Reaction when releasing the button <i>(Only visible for object type "Percent")</i>	<b>no reaction</b>
	Value 0% - 100%
Value in percent <i>(Only visible for value 0%-100%)</i>	0 - 100 [0]

## Objects for operating mode "Switching"

No.	Name	Function	C	R	W	T	U
117	IR1: Output (DPT 1.001)	Switching	C	-	W	T	-
121	IR1: Output (DPT 1.x)	Feedback toggle mode	C	-	W	-	-
122	IR2: Output (DPT 1.001)	Switching	C	-	W	T	-
126	IR2: Output (DPT 1.x)	Feedback toggle mode	C	-	W	-	-
127	IR3: Output (DPT 1.001)	Switching	C	-	W	T	-
131	IR3: Output (DPT 1.x)	Feedback toggle mode	C	-	W	-	-
132	IR4: Output (DPT 1.001)	Switching	C	-	W	T	-
136	IR4: Output (DPT 1.x)	Feedback toggle mode	C	-	W	-	-
137	IR5: Output (DPT 1.001)	Switching	C	-	W	T	-
141	IR5: Output (DPT 1.x)	Feedback toggle mode	C	-	W	-	-

## Objects for the operating mode "forced operation"

No.	Name	Function	C	R	W	T	U
117	IR1: Output (DPT 2.001)	forced operation	C	-	-	T	-
122	IR2: Output (DPT 2.001)	forced operation	C	-	-	T	-
127	IR3: Output (DPT 2.001)	forced operation	C	-	-	T	-
132	IR4: Output (DPT 2.001)	forced operation	C	-	-	T	-
137	IR5: Output (DPT 2.001)	forced operation	C	-	-	T	-

## Objects for the operating mode "value in %"

No.	Name	Function	C	R	W	T	U
117	IR1: Output (DPT 5.001)	Value	C	-	-	T	-
122	IR2: Output (DPT 5.001)	Value	C	-	-	T	-
127	IR3: Output (DPT 5.001)	Value	C	-	-	T	-
132	IR4: Output (DPT 5.001)	Value	C	-	-	T	-
137	IR5: Output (DPT 5.001)	Value	C	-	-	T	-

### 17.2.2 Operating mode "Regulation"

For regulation, a distinction is made between long and short button presses. A short press switches the light on or off, a long one dims it up or down.

**Note:** In toggle mode, it is necessary for the detector to receive a reaction if the light is switched over from an external source. Either the external toggling is performed via the object/group address "Regulation", which the detector also uses, or the actuator sends a reaction that must then be placed on the object/group address "Feedback toggle mode". Both options are equivalent.

IRx: IR channel	
Mode	<b>Switching</b> Regulation Blinds/rollers Scene
long button press from <i>(only visible in the operating mode "regulation")</i>	300 ms – 5,0 s <b>[600 ms]</b>

IRx: IR channel	
Regulation direction <i>(only visible in the operating mode "regulation")</i>	brighter and darker (toggle) <b>brighter</b> darker
Regulation step + in percent <i>(only visible in the operating mode "regulation brighter and darker (toggle)")</i>	100 – 1,5 <b>[100]</b>
Regulation step - in percent <i>(only visible in the operating mode "regulation brighter and darker (toggle)")</i>	100 – 1,5 <b>[100]</b>

No.	Name	Function	C	R	W	T	U
117	IR1: Output (DPT 1.001)	Switching	C	-	W	T	-
118	IR1: Output (DPT 3.007)	Regulation command	C	-	W	T	-
121	IR1: Output (DPT 1.x)	Feedback toggle mode	C	-	W	-	-
122	IR2: Output (DPT 1.001)	Switching	C	-	W	T	-
123	IR2: Output (DPT 3.007)	Regulation command	C	-	W	T	-
126	IR2: Output (DPT 1.x)	Feedback toggle mode	C	-	W	-	-
127	IR3: Output (DPT 1.001)	Switching	C	-	W	T	-
128	IR3: Output (DPT 3.007)	Regulation command	C	-	W	T	-
131	IR3: Output (DPT 1.x)	Feedback toggle mode	C	-	W	-	-
132	IR4: Output (DPT 1.001)	Switching	C	-	W	T	-
133	IR4: Output (DPT 3.007)	Regulation command	C	-	W	T	-
136	IR4: Output (DPT 1.x)	Feedback toggle mode	C	-	W	-	-
137	IR5: Output (DPT 1.001)	Switching	C	-	W	T	-
138	IR5: Output (DPT 3.007)	Regulation command	C	-	W	T	-
141	IR5: Output (DPT 1.x)	Feedback toggle mode	C	-	W	-	-

### 17.2.3 Operating mode "Shutters/blinds"

The step and move commands are required in order to control shutters and/or blinds. These can be defined via a short or long button press. A long button press triggers the move command and a short button can stop it or continue it in steps.

As a rule, multiple step commands are given in succession in order to adjust the slats. A change in direction can only take place once the time window has expired.

**Note:** In toggle mode, it is necessary for the detector to receive a reaction if the shutters/blinds are controlled from an external source. Either the external toggling is performed via the object/group address "move command", which the detector also uses, or the actuator sends a reaction that must then be placed on the object/group address "feedback toggle mode". Both options are equivalent.

IRx: IR channel	
Mode	<b>Switching</b> Regulation Blinds/roller shutter Scene
long button press <i>(only visible in the operating mode "Shutters/blinds")</i>	300 ms – 5,0 s <b>[600 ms]</b>



IRx: IR channel	
Reaction to short button press <i>(only visible in the operating mode "Shutters/blinds")</i>	no reaction <b>step up</b> step down step up/down (toggle)
Step in same direction <i>(only visible in the operating mode "Shutters/blinds by")</i>	500ms – 5,0 s <b>[2,0 s]</b>
Reaktion bei langem Tastendruck <i>(only visible in the operating mode "Shutters/blinds by")</i>	no reaction <b>move up</b> move down move up/down (toggle)

No.	Name	Function	C	R	W	T	U
117	IR1: Output (DPT 1.007)	Slats stop/ step command	C	-	W	T	-
118	IR1: Output (DPT 1.008)	Move command	C	-	W	T	-
121	IR1: Output (DPT 1.x)	Feedback toggle mode	C	-	W	-	-
122	IR2: Output (DPT 1.007)	Slats stop/ step command	C	-	W	T	-
123	IR2: Output (DPT 1.008)	Move command	C	-	W	T	-
126	IR2: Output (DPT 1.x)	Feedback toggle mode	C	-	W	-	-
127	IR3: Output (DPT 1.007)	Slats stop/ step command	C	-	W	T	-
128	IR3: Output (DPT 1.008)	Move command	C	-	W	T	-
131	IR3: Output (DPT 1.x)	Feedback toggle mode	C	-	W	-	-
132	IR4: Output (DPT 1.007)	Slats stop/ step command	C	-	W	T	-
133	IR4: Output (DPT 1.008)	Move command	C	-	W	T	-
136	IR4: Output (DPT 1.x)	Feedback toggle mode	C	-	W	-	-
137	IR5: Output (DPT 1.007)	Slats stop/ step command	C	-	W	T	-
138	IR5: Output (DPT 1.008)	Move command	C	-	W	T	-
141	IR5: Output (DPT 1.x)	Feedback toggle mode	C	-	W	-	-

#### 17.2.4 Operating mode "Scene"

A scene serves to combine specific "switching states" that are partially dependent on one another.

For example, different scenes can be set up in the living and dining area for eating or watching television. To this end, the lighting, shade and even the actuator technology of the sockets can optionally be combined with one another. For example, in the scene "Watching television", the lighting can be dimmed to a low level and the blinds/ shutters can be closed. In the commercial sphere, scenes may be useful in conference rooms. As an example: In the scene "Meeting", all lamps are at 100%, while in the scene "Presentation", the lights are dimmed, the shutters closed and the projection screen rolled down.

Scenes can be learned and called up. In the parameters, the corresponding scene number 0-63 can be selected and with the "Learn scene" parameter active, the corresponding scene can be taught in with a long button press.

IRx: IR channel	
Mode	<b>Switching</b> Regulation Blinds/roller shutter Scene
Scene number <i>(only visible in the operating mode "Scene")</i>	1 - 63 <b>[1]</b>
Learn scene <i>(only visible in the operating mode "Scene")</i>	deactivated <b>activated</b>
Long button press <i>(only visible in the operating mode "Scene")</i>	300 ms – 5,0 s <b>[5,0 s]</b>

No.	Name	Function	C	R	W	T	U
117	IR1: Output (DPT 18.001)	Scene	C	-	-	T	-
122	IR2: Output (DPT 18.001)	Scene	C	-	-	T	-
127	IR3: Output (DPT 18.001)	Scene	C	-	-	T	-
132	IR4: Output (DPT 18.001)	Scene	C	-	-	T	-
137	IR5: Output (DPT 18.001)	Scene	C	-	-	T	-

#### 17.2.5 General settings of the 5-button remote control

##### Debounce time

This configurable time describes the amount of time for which the signal must exist before it can be evaluated. The debounce time prevents brief disturbances from being detected as the signal.

IRx: IR channel	
Debounce time	<b>30ms</b> 50ms 70ms 100ms 150ms 200ms

##### Locking function

The function of an individual IR channel can be locked during runtime. The locking is effected via a "1" telegram to the corresponding lock object. The reaction upon locking and unlocking can be freely selected. The reaction depends on the operating mode selected.

IRx: IR channel	
Locking function	<b>deactivated</b> activated
reaction upon locking <i>(only visible in "Switching" mode)</i>	<b>no reaction</b> same reaction as when pressing the button same reaction as when releasing the button

IRx: IR channel	
reaction upon unlocking <i>(only visible in "Switching" mode)</i>	<b>no reaction</b> same reaction as when pressing the button same reaction as when releasing the button
reaction upon locking <i>(only visible in "regulation" mode)</i>	<b>no reaction</b> switch on switch off Send brightness value 0% – 100%
Value in percent <i>(only visible for "Send brightness value")</i>	0 – 100 [0]
reaction upon unlocking <i>(only visible in "regulation" mode)</i>	<b>no reaction</b> switch on switch off Send brightness value 0% – 100%
Value in percent <i>(only visible for "Send brightness value")</i>	0 – 100 [0]
Slats - reaction upon locking <i>(only visible in "Shutters/blinds" operation)</i>	<b>no reaction</b> step up step down
Slats - reaction upon unlocking <i>(only visible in "Shutters/blinds" operation)</i>	<b>no reaction</b> step up step down
Blinds - reaction upon locking <i>(only visible in "Shutters/blinds" operation)</i>	<b>no reaction</b> move up move down
Blinds - reaction upon unlocking <i>(only visible in "Shutters/blinds" operation)</i>	<b>no reaction</b> move up move down
Scene - reaction upon locking <i>(only visible in "Scene" mode)</i>	<b>no reaction</b> Call up scene
Scene - reaction upon unlocking <i>(only visible in "Scene" mode)</i>	<b>no reaction</b> Call up scene

No.	Name	Function	C	R	W	T	U
120	IR1: Input (DPT 1.001)	Lock	C	-	W	-	-
125	IR2: Input (DPT 1.001)	Lock	C	-	W	-	-
130	IR3: Input (DPT 1.001)	Lock	C	-	W	-	-
135	IR4: Input (DPT 1.001)	Lock	C	-	W	-	-
140	IR5: Input (DPT 1.001)	Lock	C	-	W	-	-

#### Reaction on bus voltage return

The behaviour after return of voltage to the bus can be selected. The reaction depends on the operating mode selected.

**Note:** In the "Regulation" mode, the light can jump to a value (0-100%) after bus voltage loss. Regulation value objects are used for this.

IRx: IR channel	
Reaction upon bus voltage return <i>(only visible in "Lock" mode)</i>	<b>no reaction</b> same reaction as when pressing the button same reaction as when releasing the button
Reaction upon bus voltage return <i>(only visible in "regulation" mode)</i>	<b>no reaction</b> switch on switch off Send brightness value 0% – 100%
Value in percent <i>(only visible for "Send brightness value")</i>	0 – 100 [0]
Slats - reaction upon bus voltage return <i>(only visible in "Shutters/blinds" operation)</i>	<b>no reaction</b> Step up Step down
Blinds - reaction upon bus voltage return <i>(only visible in "Shutters/blinds" operation)</i>	<b>no reaction</b> move up move down
Scene - reaction upon bus voltage return <i>(only visible in "Scene" mode)</i>	<b>no reaction</b> call up scene

No.	Name	Function	C	R	W	T	U
119	IR1: Output (DPT 5.001)	Regulation value	C	-	-	T	-
124	IR2: Output (DPT 5.001)	Regulation value	C	-	-	T	-
129	IR3: Output (DPT 5.001)	Regulation value	C	-	-	T	-
134	IR4: Output (DPT 5.001)	Regulation value	C	-	-	T	-
139	IR5: Output (DPT 5.001)	Regulation value	C	-	-	T	-

The functions stored for the buttons can be noted on the rear of the remote control.

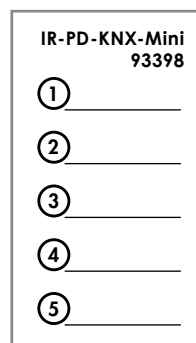

#### 17.3 Bidirectional smartphone app (with IR adapter, art. no. 92726)

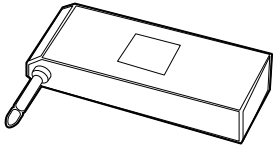

B.E.G. offers the possibility of using a free app (Android with Samsung smartphones and Apple smartphones) to read out data from the detectors and to configure settings that go beyond the functions of the configuration remote control (27 buttons). The IR adapter is required for this. This is plugged into the smartphone's audio jack. It is important that the mobile phone's volume is set to maximum to ensure reliable communication.



After the app has been installed on the smartphone, you can open it via the corresponding icon.



After the start screen, you are automatically taken to the introduction page at parameter level. Here you immediately have the opportunity to read out data from the detector via the  button. To do this, point the adapter towards the detector.

Successful communication is acknowledged via the  symbol. If no connection is established, this is acknowledged via the  symbol. In this case, please try the procedure again. If the read-out procedure was successful, all readable parameters of the detector are shown in the list.

In the settings, a distinction is made between parameters and commands.

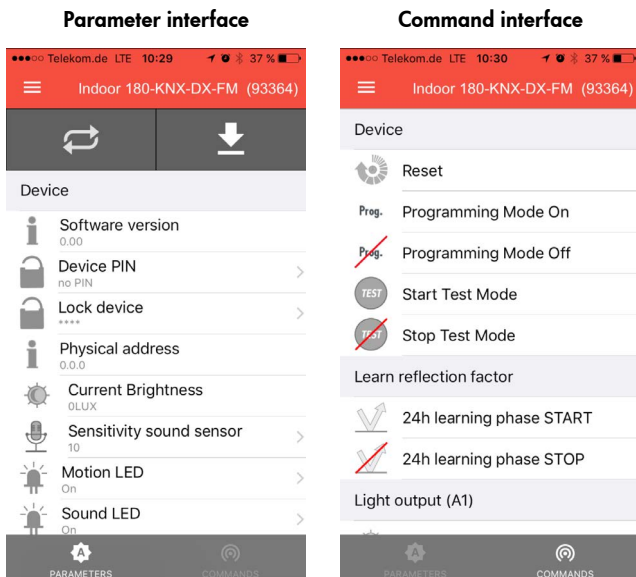

In the parameter interface, values which have been read out from the detector can be changed. The commands are identical to the commands of the 27-button remote control and cannot be read out.

### 17.3.1 Basic parameter settings

At the parameter level, various data can be read out and modified.

Device parameter	
General	Software version
	Device PIN
	Physical address
	Current brightness value
	Sound sensor sensitivity
	Motion LED status
	Sound sensor LED status
	Artificial light value at ceiling
	Artificial light value at work surface
	Daylight value at ceiling
	Daylight value at work surface
	Mixed light at ceiling
	Mixed light at work surface

### Software version

Here, the current software version of the detector is shown, so that this can be given to Support in the event of any questions.

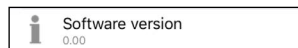

### IR-PIN

If the app is used to access the detector, the PIN must first be entered. This is defined in the ETS basic settings. Otherwise, the only available option is to read out the parameters. Settings can only be changed once the correct PIN has been entered and the corresponding parameters released.

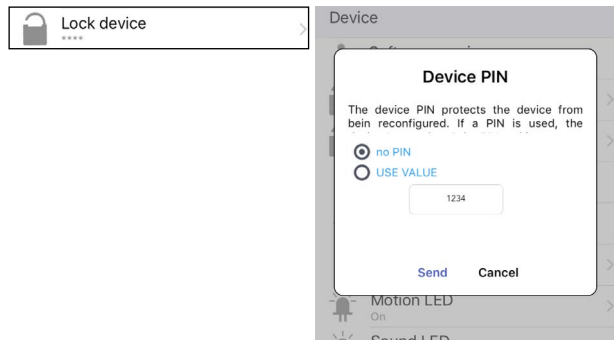

### Physical address

The physical address of the detector can be displayed. The customer can therefore identify the detector in ETS without having to uninstall it.

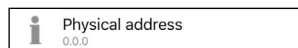

### Current brightness value

The detector can output the currently measured brightness value, taking into account the reflection factors. This can be sent to the bus or displayed via the app. It is therefore possible to use the displayed value for the light measurement parameters.



### Sensitivity of the sound sensor

If this parameter is released in ETS, the sensitivity can be read out or changed via the app, with "10" being the maximum sensitivity. At "0", the sound sensor is deactivated.

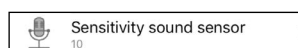

### Status of motion/IR/sound sensor LED

The status of the motion LED and sound sensor LED can also be read out. If the parameters are released accordingly in the basic settings, they can also be switched on and off via the app.



### Light measurement

The light values of the following parameters are required for adjusting the light measurement (reflection factor).

#### Artificial light value at ceiling



The light value of the artificial light that is measured at the installation site of the detector is output here. This value is required so that it and the value measured at the work surface can be used to calculate the reflection factor. The room should be darkened for this so that only the artificial light component is measured.

#### Artificial light value at work surface



If the standard settings are not adequate, the measured value at the table can be input via ETS or the app. The room should be darkened for this so that only the artificial light component is measured. Based on this value and the measured value below the ceiling, the detector calculates the reflection factor in the room. In addition, the measurement should be repeated without artificial light with open blinds.

#### Daylight value at ceiling



The light value of the daylight that is measured at the installation site of the detector is output here. This value is required so that it and the value measured at the work surface can be used to calculate the reflection factor. The artificial light should be switched off for this so that purely the daylight portion can be measured in a non-darkened room.

#### Daylight value at work surface



Here, the light value that was measured at the work surface with the lights switched off and in a non-darkened room can be input. The detector automatically calculates the light value in the room, taking the input values into account.

### 17.3.2 Device parameters light output (A1)

For the light output (A1), the following settings can be configured via the app:

Device parameter	
Light output (A1)	Mode
	Projector/Corridor
	Follow-up time
	Switch-on threshold
	Sensitivity of the individual sensors
	Status of the sound sensor
Remaining burn-in time	



### Mode

In ongoing operation, it is possible to switch between full automatic and semi-automatic mode (see section 5.1.1)

### Projector/corridor *Corr*

Here it is possible to switch between the projector and corridor function (see section 9.2)



### Follow-up time

The follow-up time of the light output A1 can be configured here (see section 6).



### Set value/switch-on threshold

Here, depending on the operating mode, the switch-on threshold can be configured in switching mode and the set value in regulation mode (see sections 7 and 11.1)



### Sensitivity of the individual sensors

For detectors with multiple motion sensors, the sensitivity of the individual sensors can be configured here (see section 9.11).



### Status of the sound sensor

Here, the sound sensor can be activated or deactivated (see section 3.4).



### Remaining burn-in time

In regulation mode, the remaining time is shown here when the burn-in function is activated (see section 14.2).

### 17.3.3 Device parameters (A2-A4)

Device parameter	
HVAC channels (A2-A4)	Mode
	Follow-up time
	Switch-on threshold
	Sensitivity of the individual sensors
	Status of the sound sensor



### Mode

In ongoing operation, it is possible to switch between full automatic and semi-automatic mode (see section 5.1.1)



### Follow-up time

The follow-up time of channels A2-A4 can be configured here (see section 6).



### Switch-on threshold

The switch-on threshold can be configured here (see section 7)

### Sensitivity of the individual sensors



For detectors with multiple motion sensors, the sensitivity of the individual sensors can be configured here (see section 9.11).

### Status of the sound sensor



Here, the sound sensor can be activated or deactivated (see section 3.4).

### 17.3.4 Slave output settings (A4)

Device parameter	
Slave output (A4)	Sensitivity of the individual sensors
	Status of the sound sensor

### Sensitivity of the individual sensors



For detectors with multiple motion sensors, the sensitivity of the individual sensors can be configured here (see section 9.11).

### Status of the sound sensor



Here, the sound sensor can be activated or deactivated (see section 3.4).

### 17.3.5 Commands for basic settings

At the command level, the following commands can be executed:

Commands	
General	Restart
	Programming mode on
	Programming mode off
	Start test mode
	Stop test mode
	Start 24-hour learning
	Stop 24-hour learning

### Restart



The detector is reset and starts up again.

### Programming mode on/off



The programming mode for the physical address of the detector can be activated via the app. It is therefore not necessary to press the programming knob on the device.

### Start/stop test mode



Here, the test mode can be activated/deactivated (see section 3.2).

### Start/stop learning phase



The 24-hour learning phase to determine the reflection factor can be activated/deactivated here. (see section 4.3.4)

### 17.3.6 Commands for light output (A1)

Commands	
Light output (A1)	On
	Off
	Lighter
	Darker
	Start lock function
	Stop lock function
	Save brightness
	Start burn-in function
	Stop burn-in function
	Start presence simulation
	Stop presence simulation

### On/off



The light channel A1 can be switched on/off using the buttons. The behaviour of the detector depends on the settings of the "Manual switch-on" menu, which must be activated in the "Additional functions" menu (see sections 5.3 and 9.1).

### Lighter/darker



If the channel is operating in regulation mode, the lighting can be dimmed.

The size of the regulation steps via remote control can be adjusted in the "basic settings" as follows:

Basic settings	
Regulation step via remote control in percent	100
	50
	25
	12.5
	6
	3
	1.5

### Start/stop lock function



The channel can be locked or unlocked using the button. The behaviour depends on the settings in the "Lock" menu (see section 9.9)

### Save brightness



The current light value can be read in via the "eye" button. If the level drops below this stored value, the detector switches on.

### Start/stop burn-in function



The burn-in function can be started and stopped here. The behaviour depends on the "Burn-in function" settings (see section 14.2).

### Start/stop presence simulation



The presence simulation can be started/stopped using the button (see section 20).

### 17.3.7 Commands for channels A2-A4

Commands	
HVAC channels (A2-A4)	On
	Off
	Start lock function
	Stop lock function



**On/off**  
Channels A2-A4 can be switched on and off using the button. The behaviour of the detector depends on the settings of the "Manual switch-on" menu, which must be activated in the "Additional functions" menu (see sections 5.3 and 9.1).



**Start/stop lock function**  
The corresponding channel can be locked or unlocked using the button. The behaviour depends on the settings in the "Lock" menu (see section 9.9).

### 18. Short presence

**i** The parameter "Proportion of the follow-up time for short presence in %" makes it possible to reduce the follow-up time if a room is only entered briefly, for example in order to pick something up. The light is then only switched on for a certain percentage of the follow-up time.

The waiting period for the short presence can be defined. If the room is vacated within this time, the "short presence" function is active. The percentage of the follow-up time can be defined via parameters. If, for example, a follow-up time of 10 minutes is used and the proportion is set to 50%, the lights will turn off after 5 minutes once the room has been vacated within the configured start time. The configured follow-up time must be at least 1 minute.

Short presence	
Waiting period in seconds	1 ... 120 (0)

Short presence	
Proportion of the follow-up time for short presence in %	100
	50
	25
	12.5

### 19. Self-adjustment of follow-up time

**i** Upon activation of this parameter, the detector learns the switching behaviour and adapts it to the fluctuations in the room in question.

If a switch-on time of 2 minutes is used, for example, and the detector switches the light off because no movement is detected, but switches it back on again within a time window of < 20 seconds because new movement is detected, the switch-on time doubles to 4 minutes in order to prevent unnecessary switching on and off.

The detector repeats this process up to a maximum follow-up time of 30 minutes.

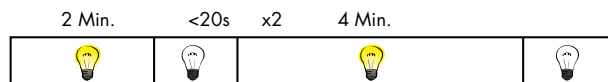

If, however, after the follow-up time has been revised upwards in this example, switching breaks of more than two minutes are detected, the detector halves the switch-on time so that it is once again 2 minutes. This process is repeated in steps, with the originally configured switch-on time as the minimum.

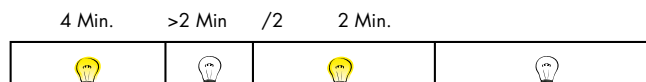

Self-adjustment of follow-up time	
(up to max. 30 minutes)	deactivated
	activated

### 20. Presence simulation

In the presence simulation, the detector switches the lights at channel A1 on and off at random. If this function is activated, a new menu appears on the right. If the level drops below the configured set value brightness or switch-on threshold, the simulation begins when this function is active. The simulation duration can be defined.

A minimum switch-on and switch-off time can be defined due to differing occupancy levels in different rooms. It is also required to define a generated random time in order to set the limits of the intervals. If, for example, a minimum switch-on time of 10 minutes and a generated random time of 20 minutes are selected, the lights remain switched on for at least 10 minutes up to a maximum of 30 minutes. The same principle applies to the switch-off time.

In heavily occupied rooms, therefore, a rather long switch-on time is selected and a short switch-off time, while the switch-off time is longer in corridors and social rooms.

After the configured simulation time has ended, the simulation ends dynamically based on the random times and automatically restarts the next day from a brightness of 100 lux until the configured switch-on threshold is exceeded. When dusk falls, the simulation is restarted. When an area is entered for which the presence simulation is active, the simulation is deactivated when movement is detected and the lights are switched/regulated for occupants in accordance with the settings. Buttons can also be used. After the person has left the area again, the simulation continues after the configured follow-up time has elapsed. The presence simulation can be activated and deactivated by addressing the group object 150 "SIMU: Input - Presence simulation start/stop".

**! A** The function is only active in the "Switching" mode if the parameter "Light-dependent switching" is activated.

Presence simulation	
SIMU	deactivated
	activated

Presence simulation	
Simulation time in hours	1 ... 24 (5)

Presence simulation	
Minimum switch-on time in minutes	1 ... 255 (10)

Presence simulation	
Additional automatically generated random switch-on time up to max. minutes	1 ... 255 (20)

Presence simulation	
Minimum switch-off time in minutes	1 ... 255 (10)

Presence simulation	
Additional automatically generated random switch-off time up to max. minutes	1 ... 255 (20)

Presence simulation	
Presence simulation start/stop	<b>via group object</b> via remote control via group object and remote control

No.	Name	Function	C	R	W	T	U
150	SIMU: Input (DPT 1.010)	Presence simulation start/stop	C	-	W	-	-

## 21. Internal pushbutton

The Indoor 140L-KNX-DX has an integrated 2-part pushbutton interface. To this end, it is possible to press on the half-shells above and below the lens.

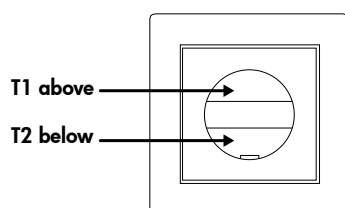

In the "Button functions" menu, the corresponding button can be activated and the push button functions can be configured on the menu that is then revealed.

The available parameters are identical to the parameters for the 5-button remote control for end-customers (see section 17.2).

Button functions	
T1 top	deactivated
T2 bottom	activated

## Switching/Regulation

No.	Name	Function	C	R	W	T	U
107	T1: Output (DPT 1.001)	Switching	C	-	W	T	-
108	T1: Output (DPT 3.007)	Regulation command	C	-	W	T	-
109	T1: Output (DPT 5.001)	Regulation value	C	-	-	T	-
111	T1: Output (DPT 1.x)	Feedback toggle mode	C	-	W	-	-

No.	Name	Function	C	R	W	T	U
112	T2: Output (DPT 1.001)	Switching	C	-	W	T	-
113	T2: Output (DPT 3.007)	Regulation command	C	-	W	T	-
114	T2: Output (DPT 5.001)	Regulation value	C	-	-	T	-
116	T2: Output (DPT 1.x)	Feedback toggle mode	C	-	W	-	-

## Shutters/blinds

No.	Name	Function	C	R	W	T	U
107	T1: Output (DPT 1.007)	Slats stop/step command	C	-	W	T	-
108	T1: Output (DPT 1.008)	Move command	C	-	W	T	-
111	T1: Output (DPT 1.x)	Feedback toggle mode	C	-	W	-	-

No.	Name	Function	C	R	W	T	U
112	T2: Output (DPT 1.007)	Slats stop/step command	C	-	W	T	-
113	T2: Output (DPT 1.008)	Move command	C	-	W	T	-
116	T2: Output (DPT 1.x)	Feedback toggle mode	C	-	W	-	-

## Scene

No.	Name	Function	C	R	W	T	U
107	T1: Output (DPT 18.001)	Scene	C	-	-	T	-

No.	Name	Function	C	R	W	T	U
112	T2: Output (DPT 18.001)	Scene	C	-	-	T	-

## 22. Logic functions

The DX variant devices have logic functions that are divided into two identical modules. Upon activation, the options appear on the right.

There are three inputs and one output for each module, where the third input must be activated separately.

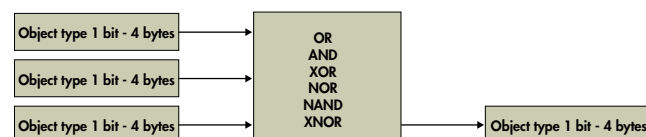

In addition to the object type, it is now possible to select whether the logic input is "0" or "1" if the selected object type is  $\geq$  or  $\leq$  a particular value. This depends on the selected object type.

The send condition of the output can be defined in the same manner as the behaviour after bus voltage return.

Logic functions	
L1/L2	<b>deactivated</b>
	activated

Logic functions	
Input 3	<b>deactivated</b>
	activated

Logic	
L1/L2	<b>OR</b>
	AND
	XOR
	NOR
	NAND
	XNOR

Input (x)	
Logic input after bus voltage return	<b>0</b>
	1

Input (x)	
Object type	<b>1bit (DPT 1.001)</b>
	1 byte percent (DPT 5.001)
	1 byte counter (DPT 5.010)
	1 byte counter with prefix (DPT 6.010)
	2 byte float (DPT 9.x)
	2 byte counter (DPT 7.x)
	2 byte counter with prefix (DPT 8.x)
	4 byte float (DPT 14.x)
	4 byte counter (DPT 12.x)
	4 byte counter with prefix (DPT 13.x)

Input (x)	
Logic input is "0" at	<b>smaller - equal</b>
	greater - equal
Value	<b>0</b>
	1

Input (x)	
Logic input is "1" at	smaller - equal
	<b>greater - equal</b>
Value	0
	<b>1</b>

Input (x)		
(3rd column default values for "0")	1bit (DPT 1.001)	<b>0</b>
	1 byte percent (DPT 5.001)	<b>20</b>
	1 byte counter (DPT 5.010)	<b>30</b>
	1 byte counter with prefix (DPT 6.010)	<b>-80</b>
	2 byte float (DPT 9.x)	<b>100</b>
	2 byte counter (DPT 7.x)	<b>100</b>
	2 byte counter with prefix (DPT 8.x)	<b>100</b>
	4 byte float (DPT 14.x)	<b>100</b>
	4 byte counter (DPT 12.x)	<b>100</b>
	4 byte counter with prefix (DPT 13.x)	<b>100</b>

Input (x)		
(3rd column default values for "1")	1bit (DPT 1.001)	<b>1</b>
	1 byte percent (DPT 5.001)	<b>80</b>
	1 byte counter (DPT 5.010)	<b>220</b>
	1 byte counter with prefix (DPT 6.010)	<b>80</b>
	2 byte float (DPT 9.x)	<b>500</b>
	2 byte counter (DPT 7.x)	<b>500</b>
	2 byte counter with prefix (DPT 8.x)	<b>500</b>
	4 byte float (DPT 14.x)	<b>500</b>
	4 byte counter (DPT 12.x)	<b>500</b>
	4 byte counter with prefix (DPT 13.x)	<b>500</b>

Output	
Send	<b>upon modification</b>
	upon modification from 0 to 1
	upon modification from 1 to 0
	upon input update

Output	
Send upon bus voltage return	deactivated
	<b>activated</b>

Output	
Object type	1bit (DPT 1.001)
	1 byte percent (DPT 5.001)
	1 byte counter (DPT 5.010)
	1 byte counter with prefix (DPT 6.010)
	2 byte float (DPT 9.x)
	2 byte counter (DPT 7.x)
	2 byte counter with prefix (DPT 8.x)
	4 byte float (DPT 14.x)
	4 byte counter (DPT 12.x)
	4 byte counter with prefix (DPT 13.x)



Output		
(3rd column default values for "0")	1bit (DPT 1.001)	<b>0</b>
	1 byte percent (DPT 5.001)	<b>0</b>
	1 byte counter (DPT 5.010)	<b>0</b>
	1 byte counter with sign (DPT 6.010)	<b>-128</b>
	2 byte float (DPT 9.x)	<b>0</b>
	2 byte counter (DPT 7.x)	<b>0</b>
	2 byte counter with sign (DPT 8.x)	<b>-1000</b>
	4 byte float (DPT 14.x)	<b>0</b>
	4 byte counter (DPT 12.x)	<b>0</b>
	4 byte counter with sign (DPT 13.x)	<b>-1000</b>

Output		
(3rd column default values for "1")	1bit (DPT 1.001)	<b>1</b>
	1 byte percent (DPT 5.001)	<b>100</b>
	1 byte counter (DPT 5.010)	<b>255</b>
	1 byte counter with sign (DPT 6.010)	<b>127</b>
	2 byte float (DPT 9.x)	<b>1000</b>
	2 byte counter (DPT 7.x)	<b>1000</b>
	2 byte counter with sign (DPT 8.x)	<b>1000</b>
	4 byte float (DPT 14.x)	<b>1000</b>
	4 byte counter (DPT 12.x)	<b>1000</b>
	4 byte counter with sign (DPT 13.x)	<b>1000</b>

No.	Name	Function	C	R	W	T	U
142	L1: Input (DPT depends on value)	Input 1	C	-	W	-	-
143	L1: Input (DPT depends on value)	Input 2	C	-	W	-	-
144	L1: Input (DPT depends on value)	Input 3	C	-	W	-	-
145	L1: Output (DPT depends on value)	Output	C	-	-	T	-
146	L2: Input (DPT depends on value)	Input 1	C	-	W	-	-
147	L2: Input (DPT depends on value)	Input 2	C	-	W	-	-
148	L2: Input (DPT depends on value)	Input 3	C	-	W	-	-
149	L2: Output (DPT depends on value)	Output	C	-	-	T	-

## 23. Summary of variants and functions

Type	PD2	PD4	PD4 - GH	PD9 - (GH)	PD11	Indoor 140L	Indoor 180	RC plus next
Variants	BA / ST / DX	BA / ST / DX	BA / ST / DX	BA / ST / DX	BA / ST / DX	BA / ST / DX	BA / ST / DX	BA / ST / DX
Functions								
Number of light sensors	1 / 2 / 2	- / 2 / 2	- / - / 2	- / - / 1	- / - / 1	- / - / 1	1 / 1 / 1	- / - / 1
Number of motion sensors	1 / 1 / 1	- / 4 / 4	- / - / 3	- / - / 1	- / - / 1	- / - / 1	1 / 1 / 1	- / - / 3
Number of HVAC outputs	1 / 3 / 3	- / 3 / 3	- / 3 / 3	- / 3 / 3	- / 3 / 3	- / 3 / 3	1 / 3 / 3	- / 3 / 3
Bidirectional remote control	- / yes / yes	- / yes / yes	- / - / yes	- / - / yes	- / - / yes	- / - / yes	- / yes / yes	- / - / yes
End-customer remote control	- / - / yes	- / - / yes	- / - / yes	- / - / yes	- / - / yes	- / - / yes	- / - / yes	- / - / yes
Temperature sensor	- / - / yes	- / - / yes	- / - / yes	- / - / yes	- / - / yes	- / - / yes	- / - / yes	- / - / yes
Sound sensor	- / - / yes	- / - / yes	- / - / yes	- / - / -	- / - / yes	- / - / -	- / - / yes	- / - / -
Logic module	- / - / yes	- / - / yes	- / - / yes	- / - / yes	- / - / yes	- / - / yes	- / - / yes	- / - / yes
Presence simulation	- / - / yes	- / - / yes	- / - / yes	- / - / yes	- / - / yes	- / - / yes	- / - / yes	- / - / yes
Internal pushbutton	- / - / -	- / - / -	- / - / -	- / - / -	- / - / -	- / - / yes	- / - / -	- / - / -
Internal orientation light	- / - / -	- / - / -	- / - / -	- / - / -	- / - / -	- / - / yes	- / - / -	- / - / -
Slave output	- / yes / yes	- / yes / yes	- / - / yes	- / - / yes	- / - / yes	- / - / yes	- / yes / yes	- / - / yes
Slave input	- / yes / yes	- / yes / yes	- / - / yes	- / - / yes	- / - / yes	- / - / yes	- / yes / yes	- / - / yes
Switching mode	yes / yes / yes	- / yes / yes	- / - / yes	yes / yes / yes	- / - / yes	- / - / yes	yes / yes / yes	- / - / yes
Regulation mode	- / yes / yes	- / yes / yes	- / - / yes	yes / yes / yes	- / - / yes	- / - / yes	- / yes / yes	- / - / yes
Burn-in function	- / yes / yes	- / yes / yes	- / - / yes	- / yes / yes	- / - / yes	- / - / yes	- / yes / yes	- / - / yes
Parameter modification via object	- / yes / yes	- / yes / yes	- / - / yes	- / - / yes	- / - / yes	- / - / yes	- / yes / yes	- / - / yes
Self-adjusting follow-up time	- / yes / yes	- / yes / yes	- / - / yes	- / - / yes	- / - / yes	- / - / yes	- / yes / yes	- / - / yes
Short presence	- / yes / yes	- / yes / yes	- / - / yes	- / - / yes	- / - / yes	- / - / yes	- / yes / yes	- / - / yes
Direction detection	no	- / yes / yes	- / - / yes	no	no	no	no	- / - / yes
Daylight-dependent switch-off	- / yes / yes	- / yes / yes	- / - / yes	- / - / yes	- / - / yes	- / - / yes	- / yes / yes	- / - / yes

## 24. List of data point types

No.	Name	Function	DPT	Flags				
<b>General</b>								
0	General: Input	Test mode	1.001 (on/off)	C	-	W	-	-
1	General: Input	Central OFF	1.001 (-/off)	C	-	W	-	-
2	General: Input	Activation motion/IR LED	1.001 (on/off)	C	-	W	-	-
3	General: Input	Activation LED sound sensor	1.001 (on/off)	C	-	W	-	-
<b>Brightness</b>								
7	Light sensor: Input	Brightness	9.004 (Lux)	C	-	W	T	U
8	Light sensor: Input	Learning start/stop	1.010 (start/stop)	C	-	W	-	-
9	Light sensor: Output	Brightness	9.004 (Lux)	C	-	-	T	-
<b>Temperature</b>								
11	Temperature sensor: Output	Temperature	9.001 (°C)	C	-	W	-	-
<b>Slave</b>								
13	SL: Input	Reset	1.002 (on/off)	C	-	W	-	-
14	SL: Input	Activation sound detection	1.002 (on/off)	C	-	W	-	-
15	SL: Input	Activation night light	1.002 (on/off)	C	-	W	-	-
16	SL: Input	Activation orientation light	1.002 (on/off)	C	-	W	-	-
18	SL: Input	Sensitivity of sensor 1	5.001 (percent)	C	-	W	-	-
19	SL: Input	Sensitivity of sensor 2	5.001 (percent)	C	-	W	-	-
20	SL: Input	Sensitivity of sensor 3	5.001 (percent)	C	-	W	-	-
21	SL: Input	Sensitivity of sensor 4	5.001 (percent)	C	-	W	-	-

No.	Name	Function	DPT	Flags				
22	SL: Input	LED control -1-	1.002 (true/false)	C	-	W	-	-
23	SL: Input	LED control -2-	1.002 (true/false)	C	-	W	-	-
24	SL: Input	LED control -3-	1.002 (true/false)	C	-	W	-	-
25	SL: Output	Slave (SL)	1.002 (true/false)	C	-	-	T	-
<b>Switch/regulate</b>								
29	A1: Input	Lock	1.001 (on/off)	C	-	W	-	-
30	A1: Input	Slave (SL)	1.002 (true/false)	C	-	W	-	-
31	A1: Input	Manual influence	1.001 (on/off)	C	-	W	-	-
32	A1: Input	External switching	1.001 (on/off)	C	-	W	-	-
33	A1: Input	External regulation	3.007 (step)	C	-	W	-	-
34	A1: Input	External value	5.001 (percent)	C	-	W	-	-
35	A1: Input	Follow-up time	7.006 (min)	C	-	W	-	-
36	A1: Input	Set value 1	9.004 (Lux)	C	-	W	-	-
		Threshold 1						
37	A1: Input	Change of threshold/set value	1.002 (true/false)	C	-	W	-	-
		S1=0, S2=1						
38	A1: Input	Change set value / fixed value	1.002 (true/false)	C	-	W	-	-
39	A1: Input	Burn-in start/stop	1.010 (start/stop)	C	-	W	-	-
40	A1: Input	Call up remaining burn-in time	1.010 (start/stop)	C	-	W	-	-
41	A1: Input	Change operat. mode VA=1, HA=0	1.002 (true/false)	C	-	W	-	-
42	A1: Input	Activation sound detection	1.001 (on/off)	C	-	W	-	-
43	A1: Input	Start value	5.001 (percent)	C	-	W	-	-
43	A1: Input	Trigger value	5.001 (percent)	C	-	W	-	-
44	A1: Input	Activation night light	1.001 (on/off)	C	-	W	-	-
45	A1: Input	Activation orientation light	1.001 (on/off)	C	-	W	-	-
46	A1: Input	Change corridor=1 projector=0	1.002 (true/false)	C	-	-	-	-
47	A1: Input	Sensitivity sensors	5.001 (percent)	C	-	W	-	-
47	A1: Input	Sensitivity sensor 1	5.001 (percent)	C	-	W	-	-
48	A1: Input	Sensitivity sensor 2	5.001 (percent)	C	-	W	-	-
49	A1: Input	Sensitivity sensor 3	5.001 (percent)	C	-	W	-	-
50	A1: Input	Sensitivity sensor 4	5.001 (percent)	C	-	W	-	-
52	A1: Output	Switching	1.001 (on/off)	C	-	-	T	-
		Value	5.001 (percent)					
		Scene	17.001 (scene no.)					
		Light group 1 (wall side)	1.001 (on/off)					
52	A1: Output	Regulation value (group near detector)	5.001 (percent)	C	-	W	T	U
53	A1: Output	Light group 2	5.001 (percent)	C	-	-	T	-
		Switching	1.001 (on/off)					
		Light group 2 (centre)	1.001 (on/off)					
54	A1: Output	Light group 3	5.001 (percent)	C	-	-	T	-
		Light group 3 (window side)	1.001 (on/off)					
56	A1: Output	Remaining burn-in time	7.006 (min)	C	-	-	T	-
57	A1: Output	LED control -1-	1.002 (true/false)	C	-	-	T	-
58	A1: Output	LED control -2-	1.002 (true/false)	C	-	-	T	-
59	A1: Output	LED control -3-	1.002 (true/false)	C	-	-	T	-
61	A1: Output	Reset	1.002 (true/false)	C	-	W	-	-
<b>HVAC 1-3</b>								
62	A2: Input	Lock	1.001 (on/off)	C	-	W	-	-
77								
92								

No.	Name	Function	DPT	Flags				
63	A?: Input	Slave (SL)	1.002 (true/false)	C	-	W	-	-
78								
93								
64	A?: Input	Manual influence	1.001 (on/off)	C	-	W	-	-
79								
94								
65	A?: Input	Follow-up time	7.006 (min)	C	-	W	-	-
80								
95								
66	A?: Input	Threshold	9.004(Lux)	C	-	W	-	-
81								
96								
67	A?: Input	Change operat. mode VA=1, HA=0	1.002 (true/false)	C	-	W	-	-
82								
97								
68	A?: Input	Activation sound detection	1.001 (on/off)	C	-	W	-	-
83								
98								
69	A?: Input	Sensitivity of sensor 1	5.001 (percent)	C	-	W	-	-
84								
99								
70	A?: Input	Sensitivity of sensor 2	5.001 (percent)	C	-	W	-	-
85								
100								
71	A?: Input	Sensitivity of sensor 3	5.001 (percent)	C	-	W	-	-
86								
101								
72	A?: Input	Sensitivity of sensor 4	5.001 (percent)	C	-	W	-	-
87								
102								
73	A?: Output	Switching	1.001 (on/off)	C	-	W	-	-
88		Value	5.001 (percent)					
103		HVAC mode	20.102 (HVACMode)					
74	A?: Output	Reset	1.002 (true/false)	C	-	W	-	-
89								
104								
<b>Button</b>								
<b>107-111,112-116,117-121,122-126,127-131,132-136,137-141</b>								
107	T?: Output	Switching	1.001 (on/off)	C	-	W		-
	T?: Output	Slats stop/step command	1.007 (step)					
107	T?: Output	Forced operation	2.001 (force)	C	-	-	T	-
	T?: Output	Value	5.001 (percent)					
		Scene	18.001 (scene ctrl.)					
108	T?: Output	Regulation command	3.007 (step)	C	-	W		-
	IR?: Output	Move command	1.008 (up/down)					
109	T?: Output	Regulation value	5.001 (percent)	C	-	-	T	-
	IR?: Output							

No.	Name	Function	DPT	Flags				
110	T?: Input	Lock	1.001 (on/off)	C	-	W	-	-
	IR?: Input							
111	T?: Input	Feedback toggle mode	1.001 (on/off)	C	-	W	-	-
	IR?: Input		1.008 (up/down)					
<b>Logic</b>								
<b>142-145, 146-149</b>								
142	Logic?: Input	Input 1	1.001 (on/off) bit	C	-	W	-	-
			5.001 (percent) 1 byte					
			5.010 (counter) 1 byte					
			6.010 (counter) 1 byte					
			7.x (counter) 2 bytes					
			8.x (counter) 2 bytes					
			9.x (KNX float) 2 bytes					
			12.x (counter) 4 bytes					
			13.x (counter) 4 bytes					
			14.x (float) 4 bytes					
143	Logic?: Input	Input 2	1.001 (on/off) bit	C	-	W	-	-
			5.001 (percent) 1 byte					
			5.010 (counter) 1 byte					
			6.010 (counter) 1 byte					
			7.x (counter) 2 bytes					
			8.x (counter) 2 bytes					
			9.x (KNXfloat) 2 bytes					
			12.x (counter) 4 bytes					
			13.x (counter) 4 bytes					
			14.x (float) 4 bytes					
144	Logic?: Input	Input 3	1.001 (on/off) bit	C	-	W	-	-
			5.001 (percent) 1 byte					
			5.010 (counter) 1 byte					
			6.010 (counter) 1 byte					
			7.x (counter) 2 bytes					
			8.x (counter) 2 bytes					
			9.x (KNX float) 2 bytes					
			12.x (counter) 4 bytes					
			13.x (counter) 4 bytes					
			14.x (float) 4 bytes					
145	Logic?: Output	Output	1.001 (on/off) bit	C	-	-	T	-
			5.001 (percent) 1 byte					
			5.010 (counter) 1 byte					
			6.010 (counter) 1 byte					
			7.x (counter) 2 bytes					
			8.x (counter) 2 bytes					
			9.x (KNX float) 2 bytes					
			12.x (counter) 4 bytes					
			13.x (counter) 4 bytes					
			14.x (float) 4 bytes					
<b>Presence simulation</b>								
150	SIMU: Input	Presence simulation start/stop	1.010 (start/stop)	C	-	W	-	-